



Lakeland Plastics, Inc.

1550 McCormick Blvd.

Mundelein, IL 60060

Phone: 1-847-680-1550

www.LakelandPlastics.com





Lakeland Plastics, Inc.

Common Extrusions with Available Tooling

Table of Contents

	Page #
1. "J" Channels.....	1-3
2. "H" Channels.....	4-5
3. "U" Channels.....	6-9
4. "C" Channels.....	10-11
5. Angles and Corners.....	12-14
6. Graphic Holders.....	15-18
7. Co-Ex Hinges.....	19-20
8. Shelf Management Systems.....	21
9. Gripper Channels.....	22
10. Shelf Front & Product Dividers.....	23
11. Wire Management.....	24
12. Slat Wall.....	25
13. Misc. Graphic Holders.....	26
14. Self Locking Graphic Holders.....	27
15. Flexible Capping or Edging.....	28

"J" CHANNELS

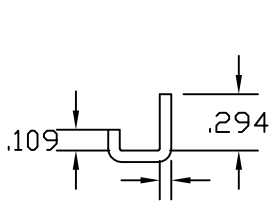

.060 P/N 852

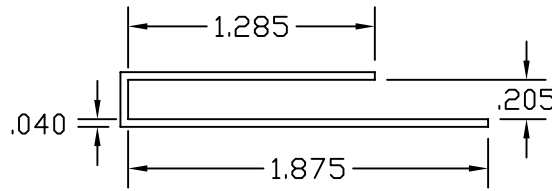

P/N 873

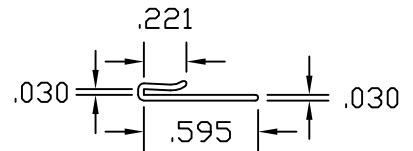

P/N 891

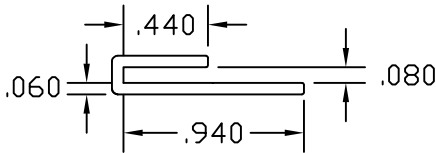

P/N 907

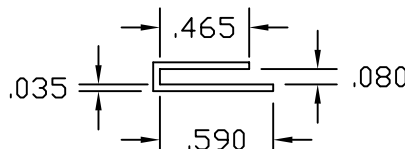

P/N 939

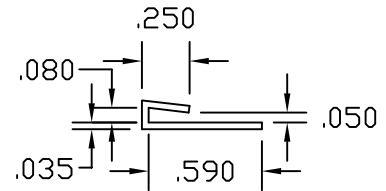

P/N 941

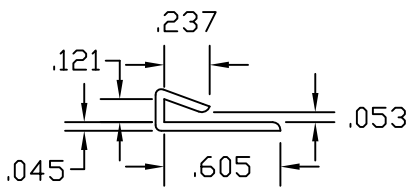

P/N 1007

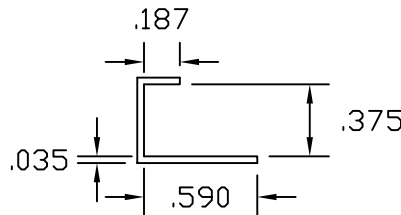

P/N 360

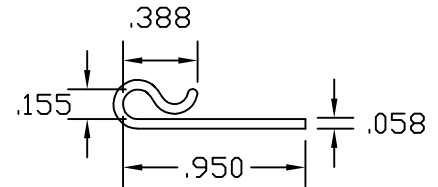

P/N 290

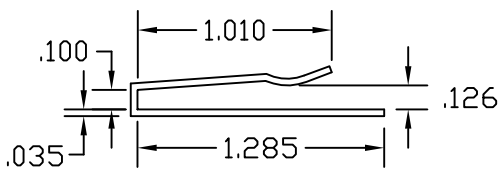

P/N 196

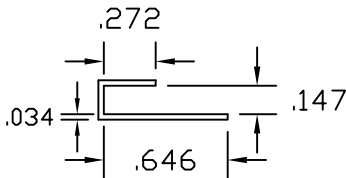

P/N 148

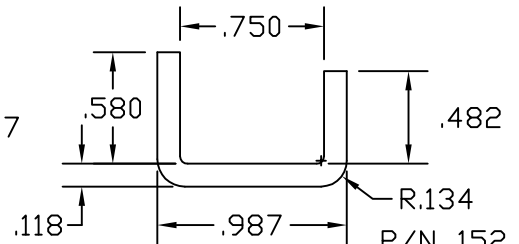

P/N 152

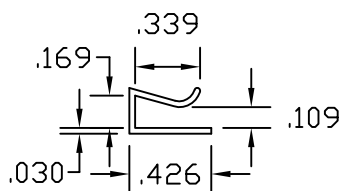

P/N 139

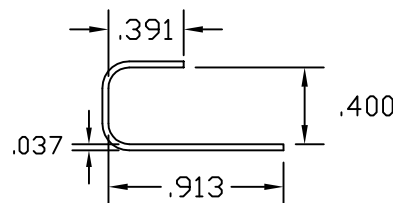

P/N 138

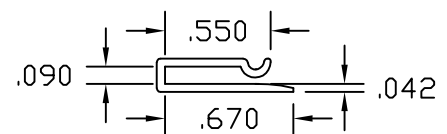

P/N 098



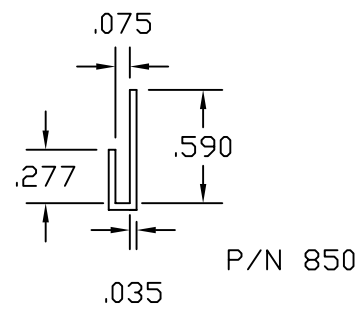
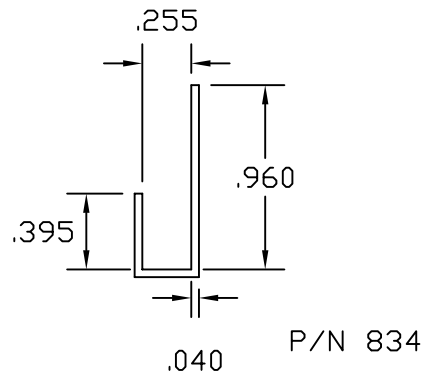
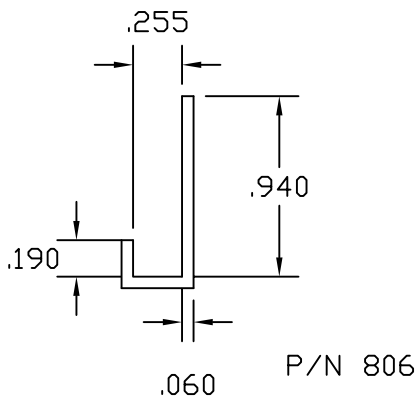
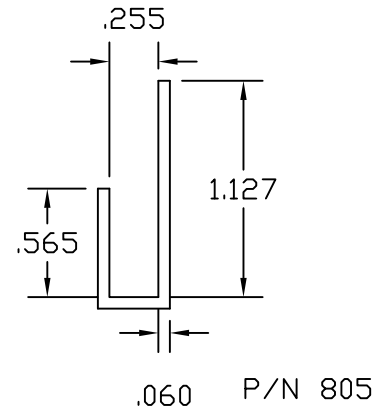
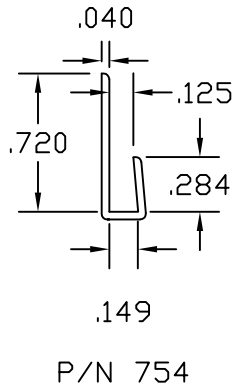
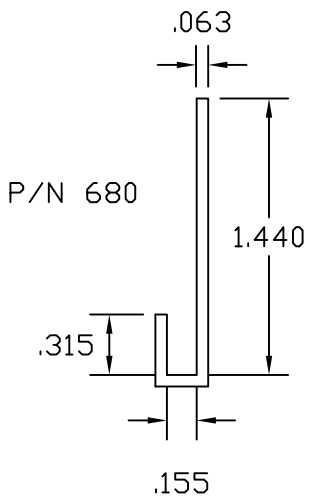
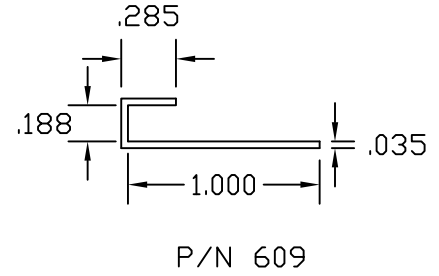
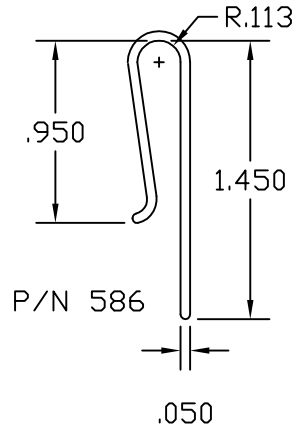
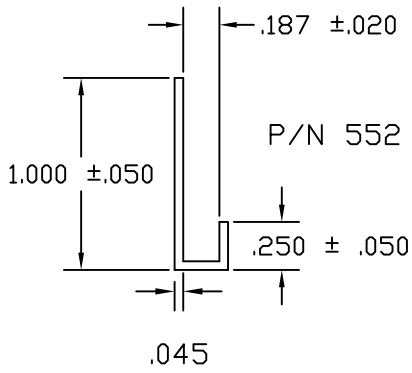
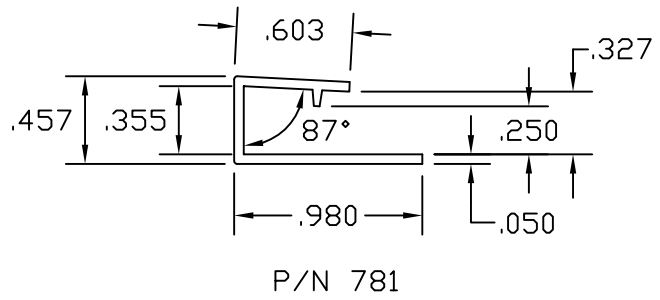
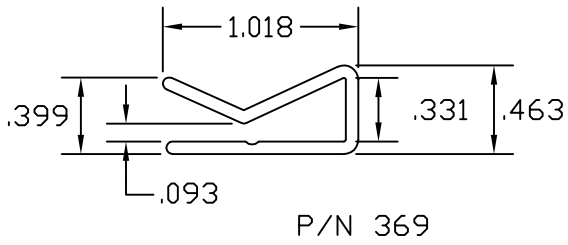

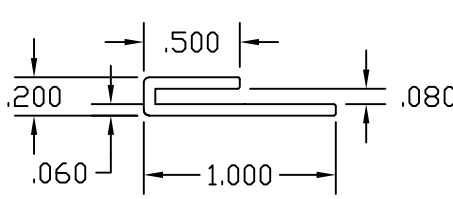

P/N 933

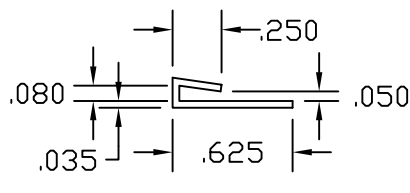

P/N 941

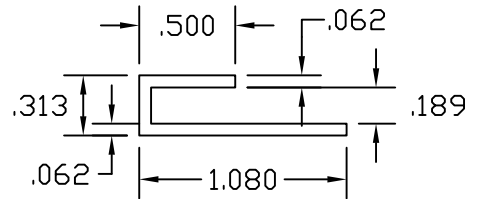

P/N 1077

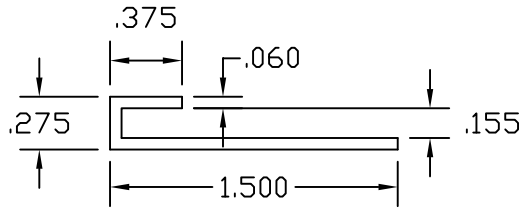

P/N 680

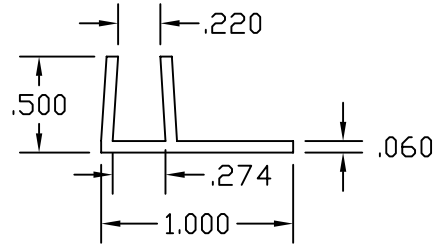

P/N 634

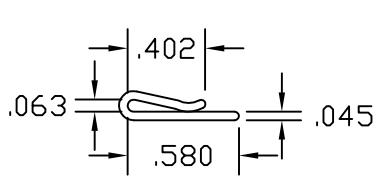

P/N 956

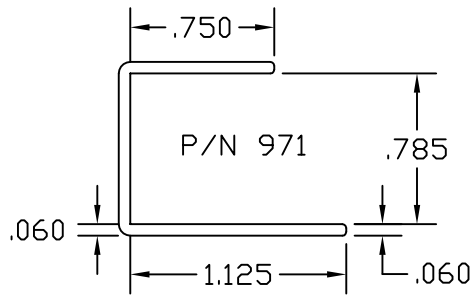

P/N 971

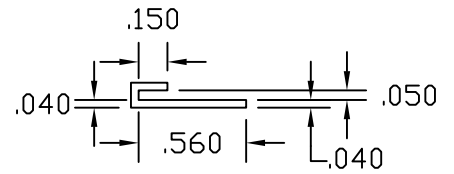

P/N 984

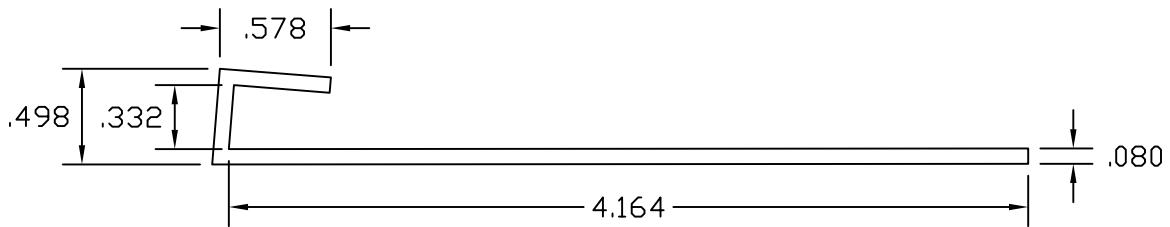

P/N 608



"H" CHANNELS

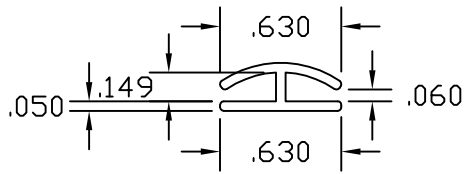

P/N 923

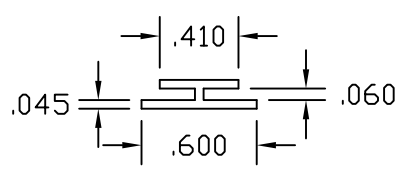

P/N 906

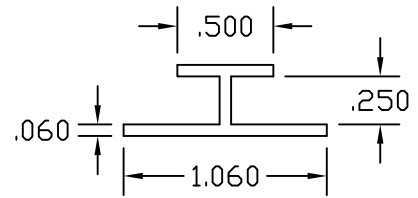

P/N 836

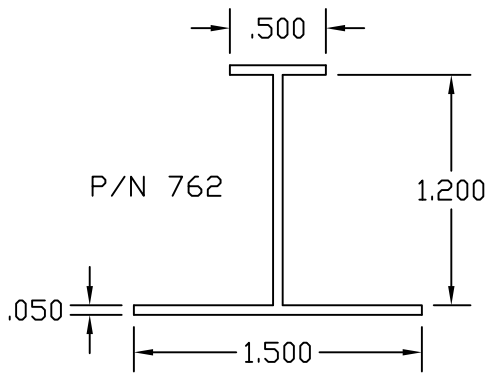

P/N 762

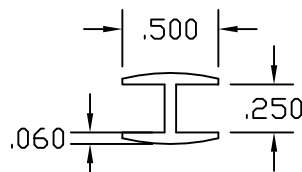

P/N 701

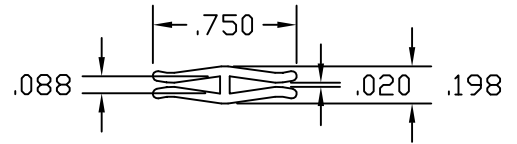

P/N 671

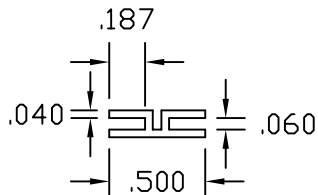

P/N 663

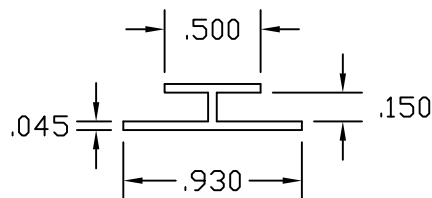

P/N 626

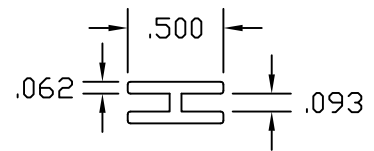

P/N 599

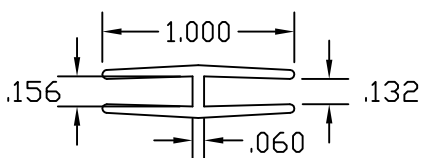

P/N 515

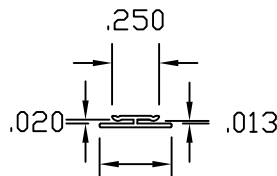

WALL: .020 P/N 465

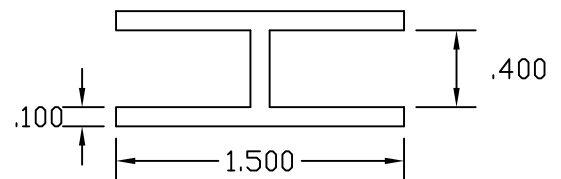

P/N 231



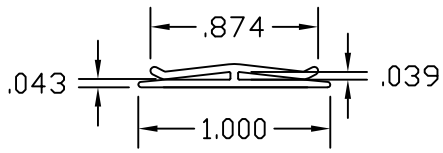

P/N 1075

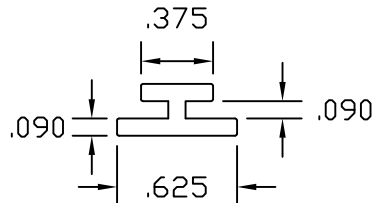

P/N 217

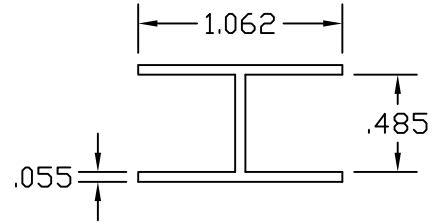

P/N 134

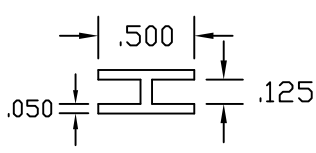

P/N 122

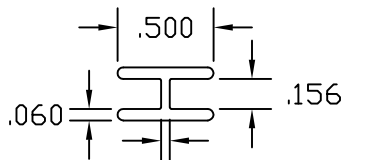

.046 P/N 068

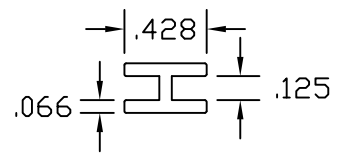

P/N 066

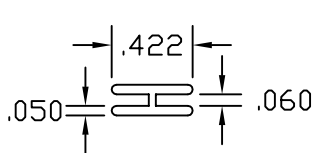

P/N 051

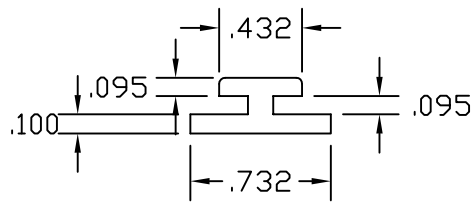

P/N 046

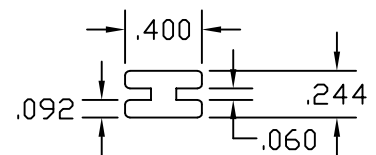

P/N 036



"U" CHANNELS

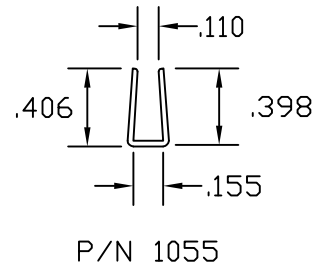
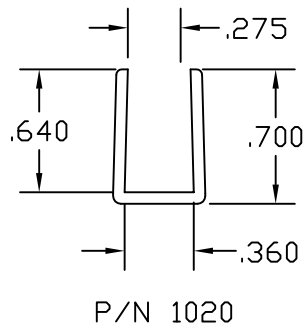
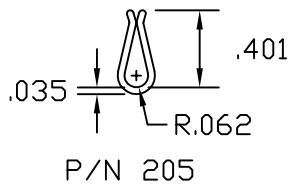
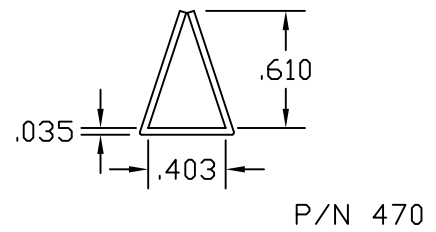
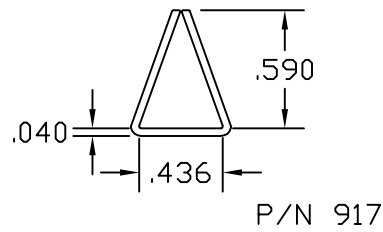
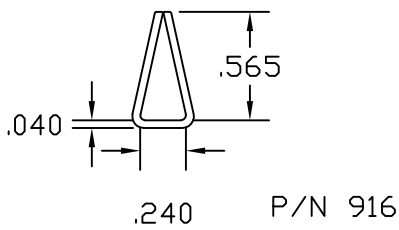
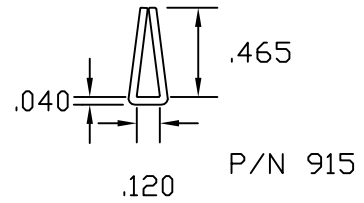
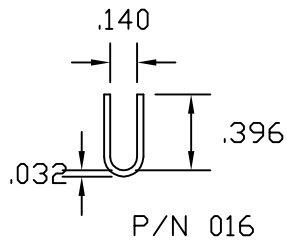
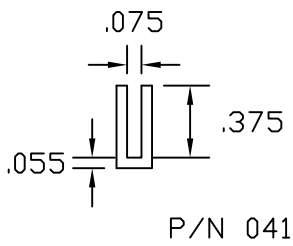
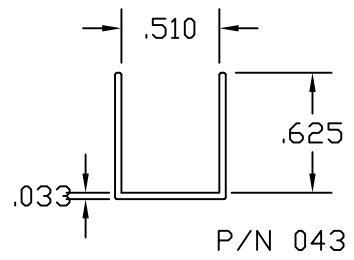
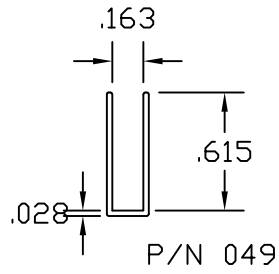
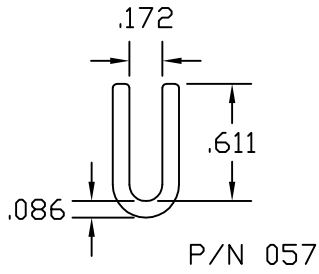

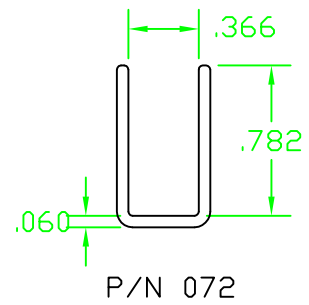
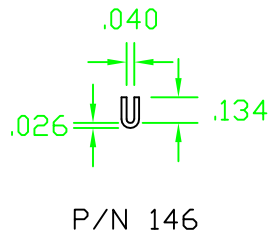
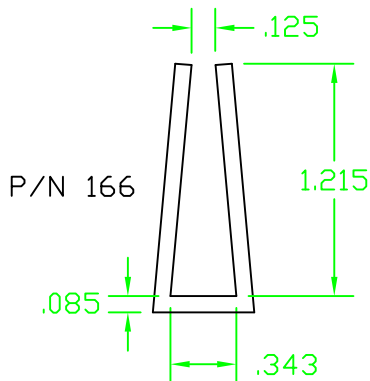
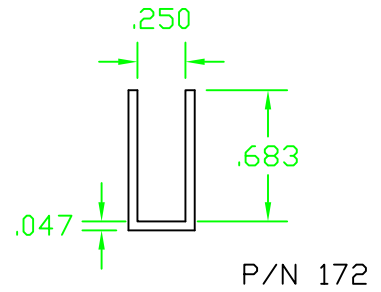
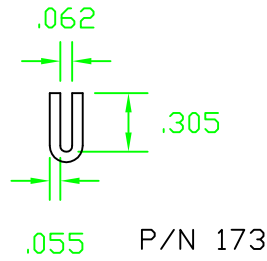
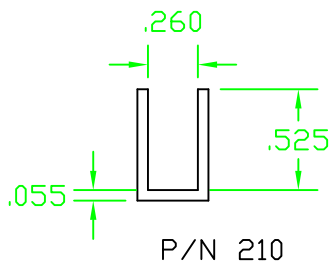
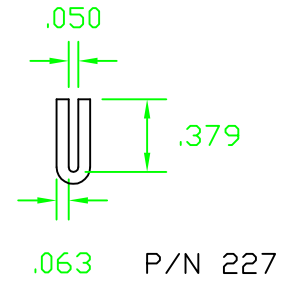
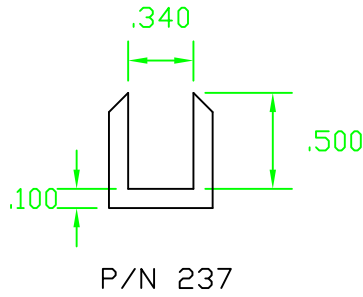
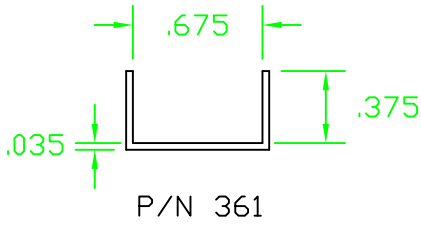
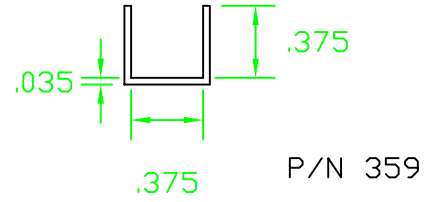
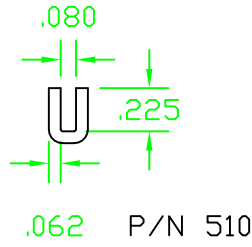
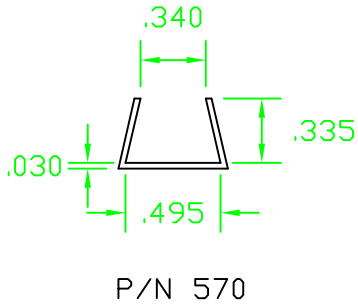
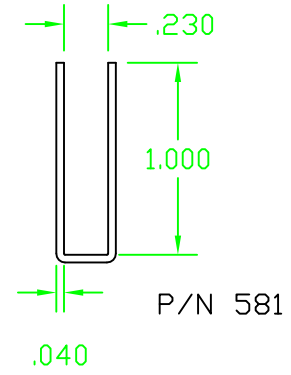
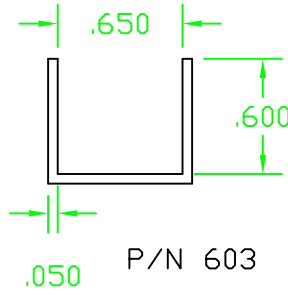
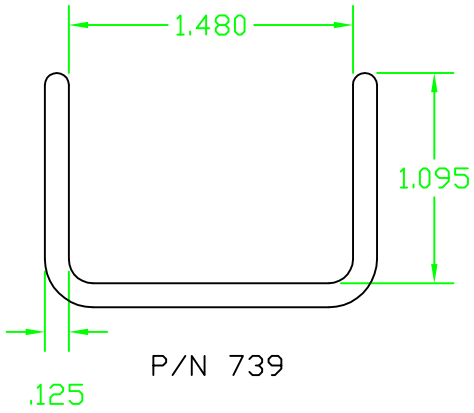

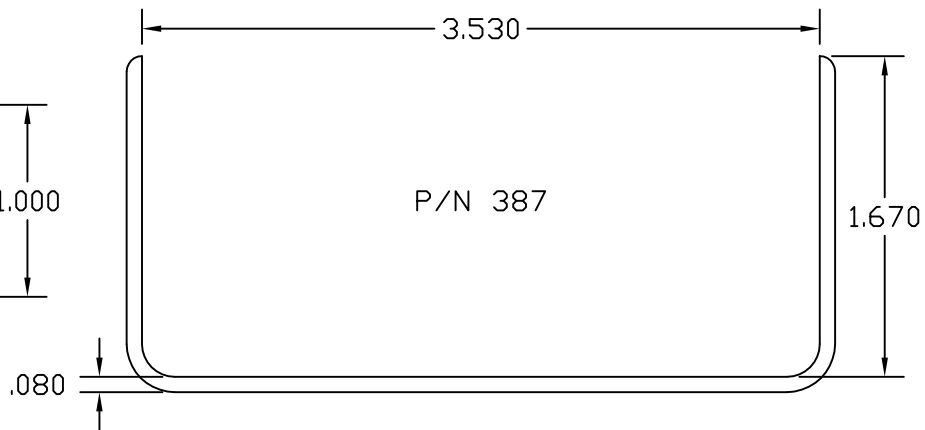
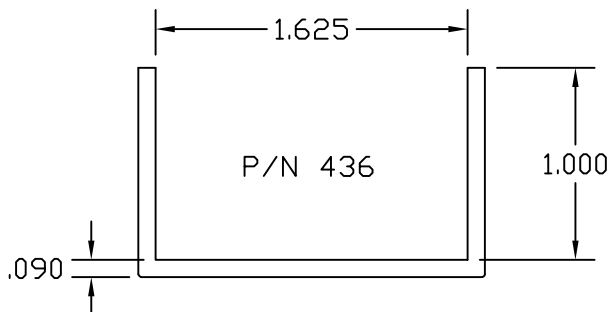
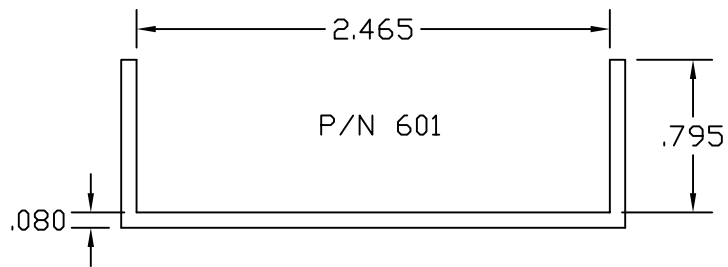
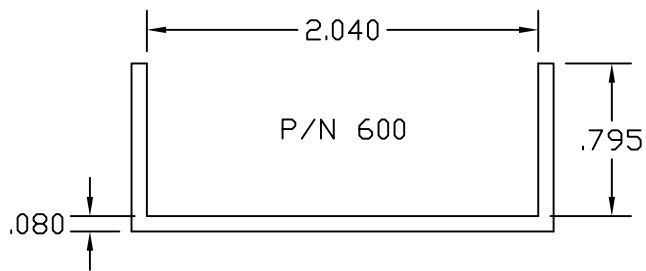
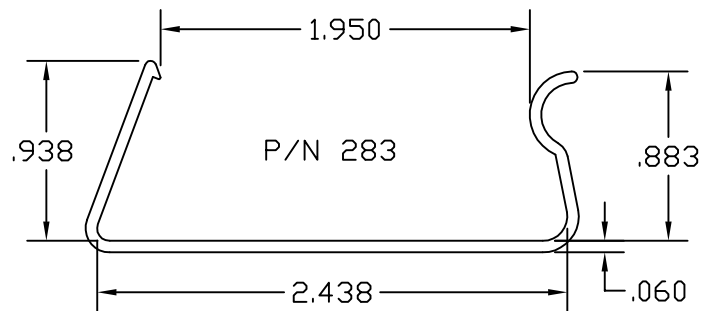
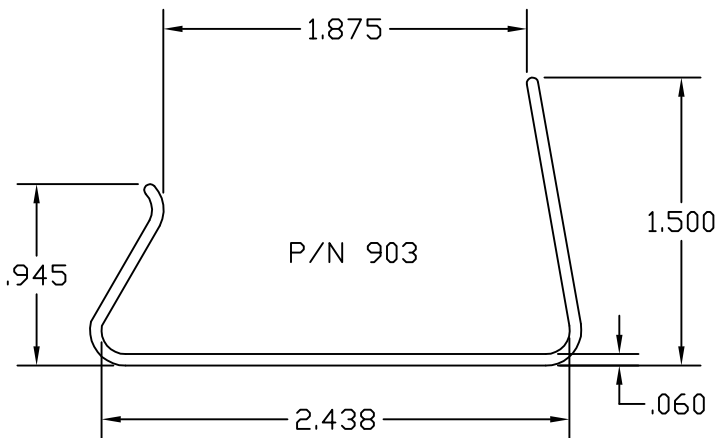
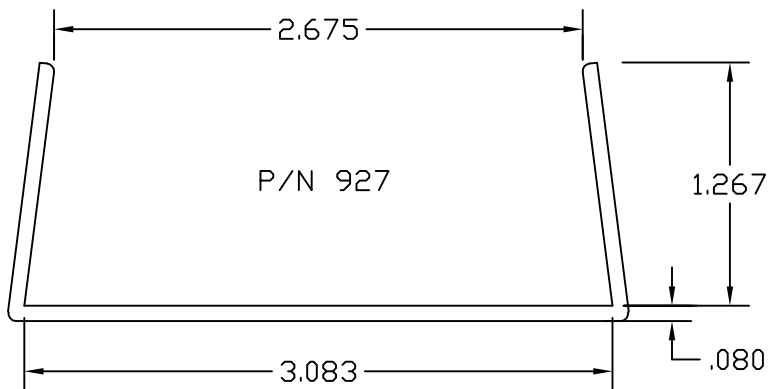
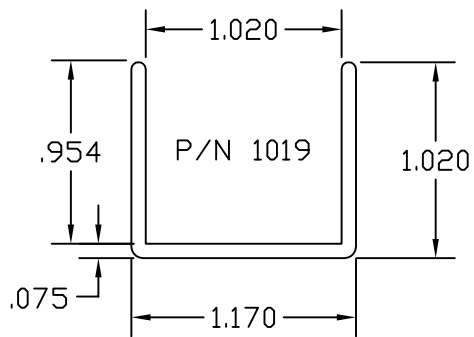

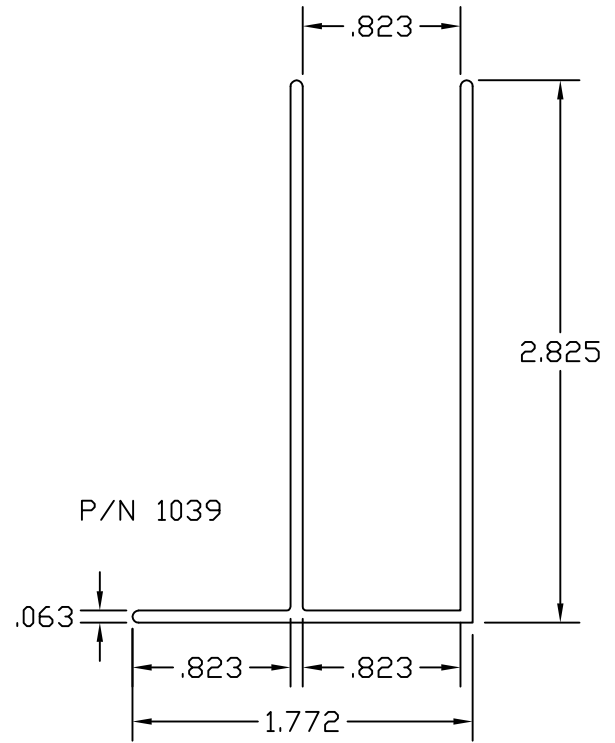
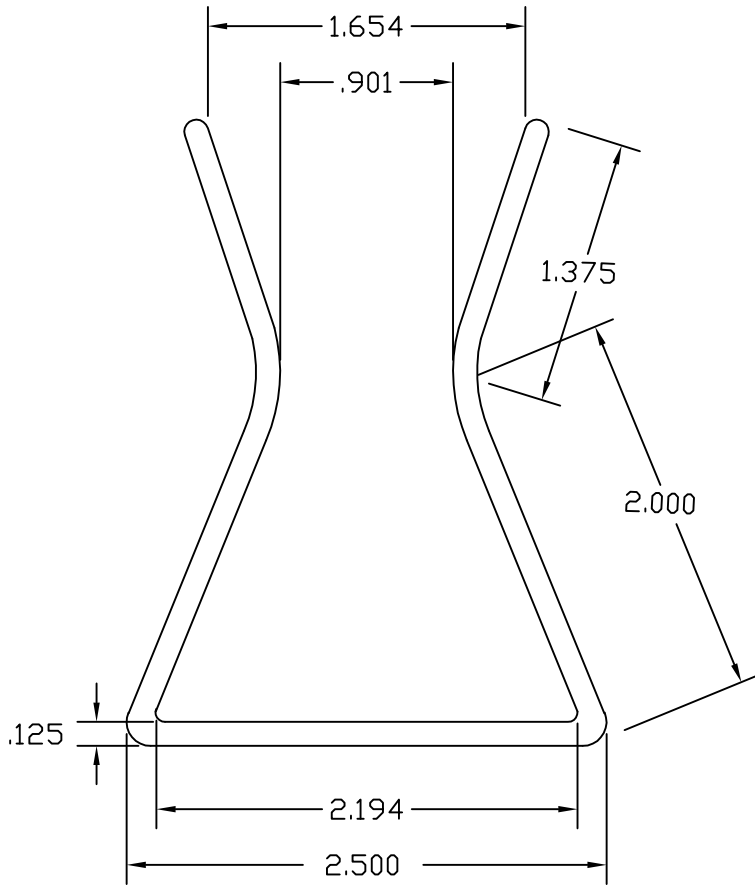
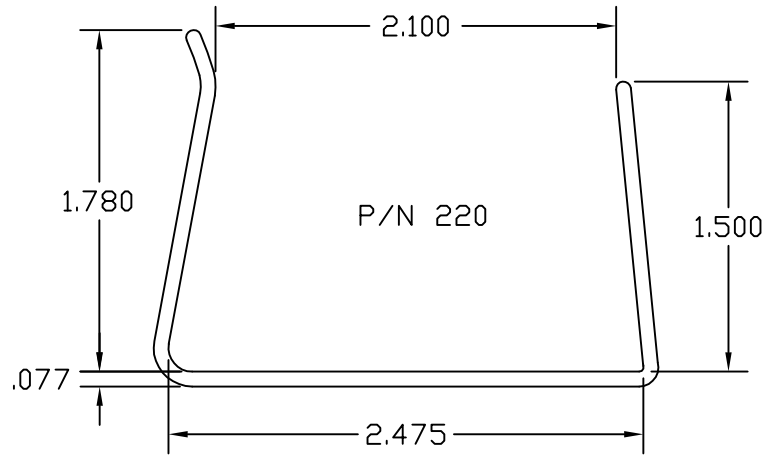
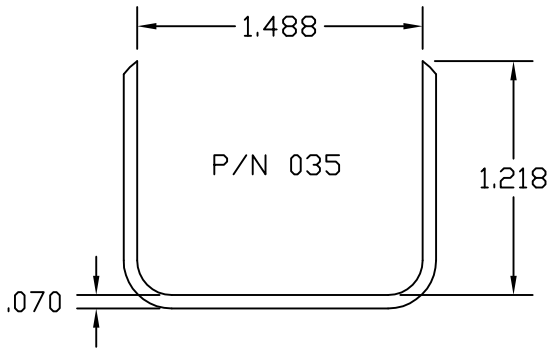

"C" CHANNELS

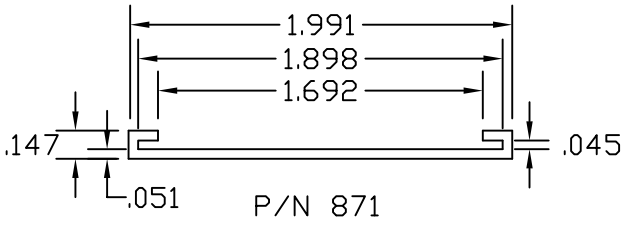

P/N 871

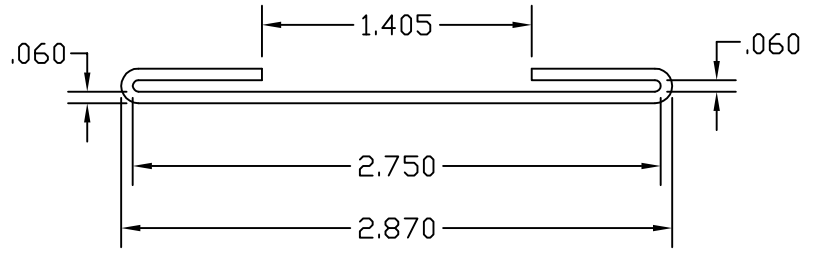

P/N 1033

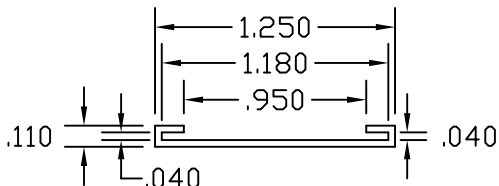

P/N 710

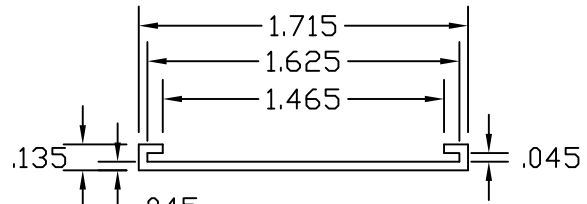

P/N 615

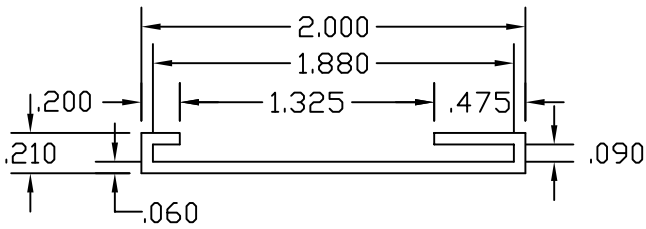

P/N 568

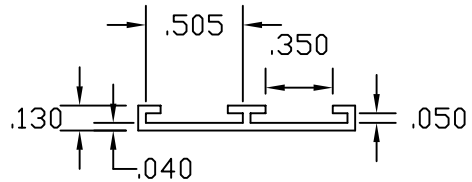

P/N 519

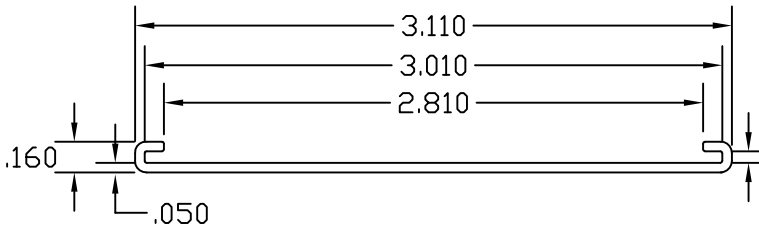

P/N 486/503

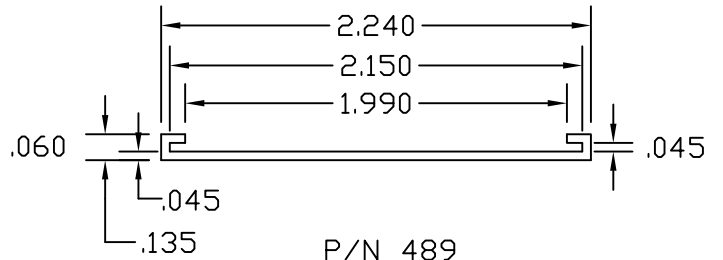

P/N 489

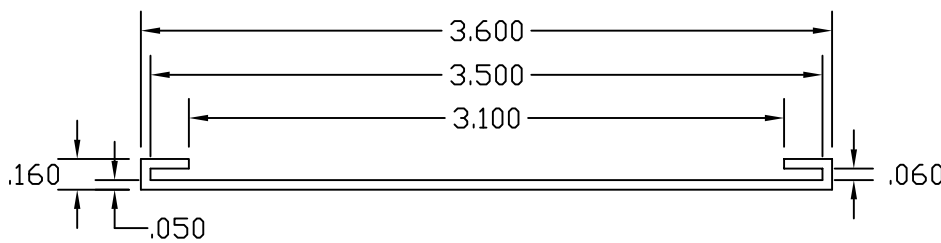

P/N 313

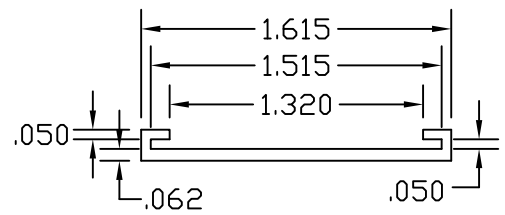

P/N 291



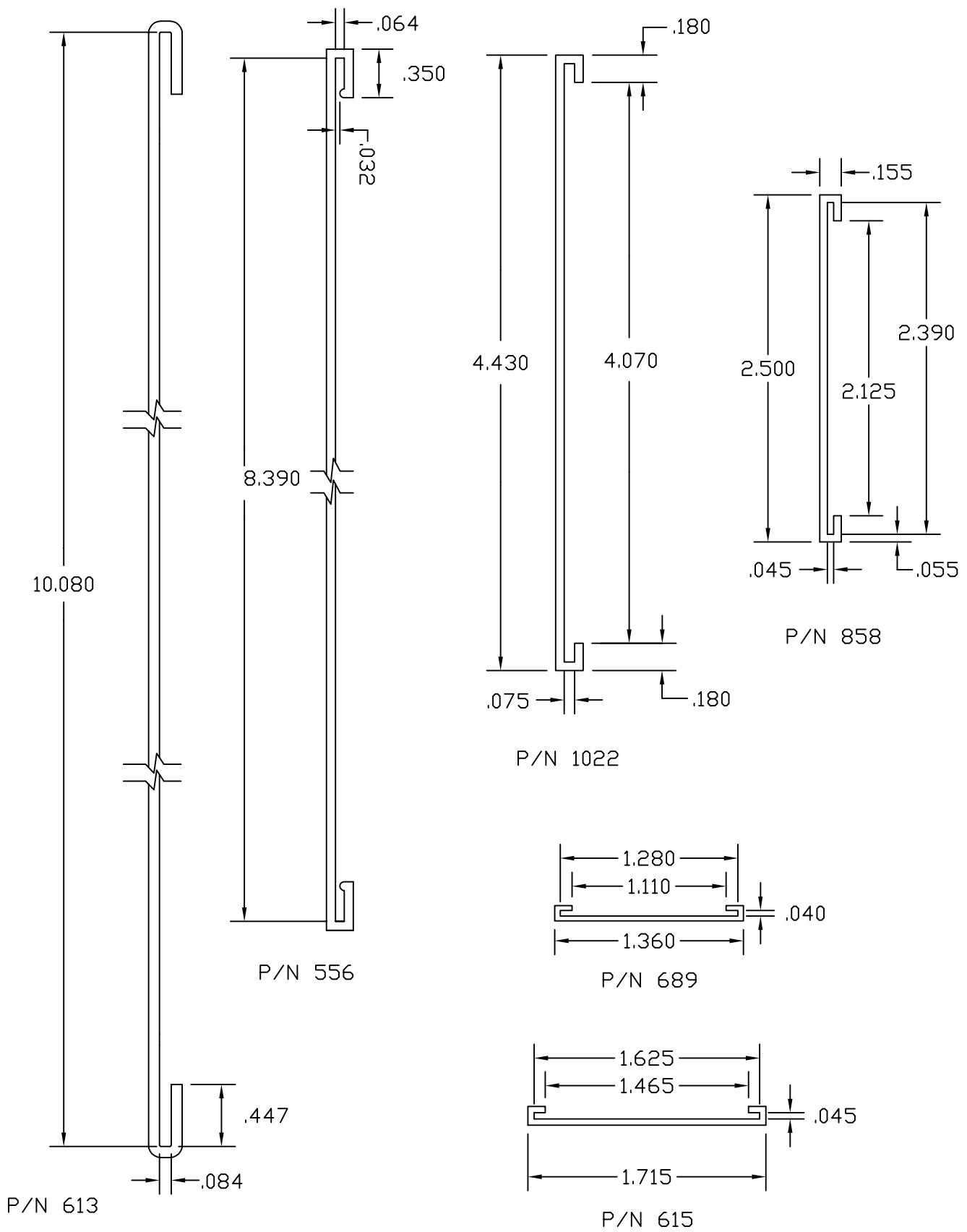

"L'S" & CORNERS

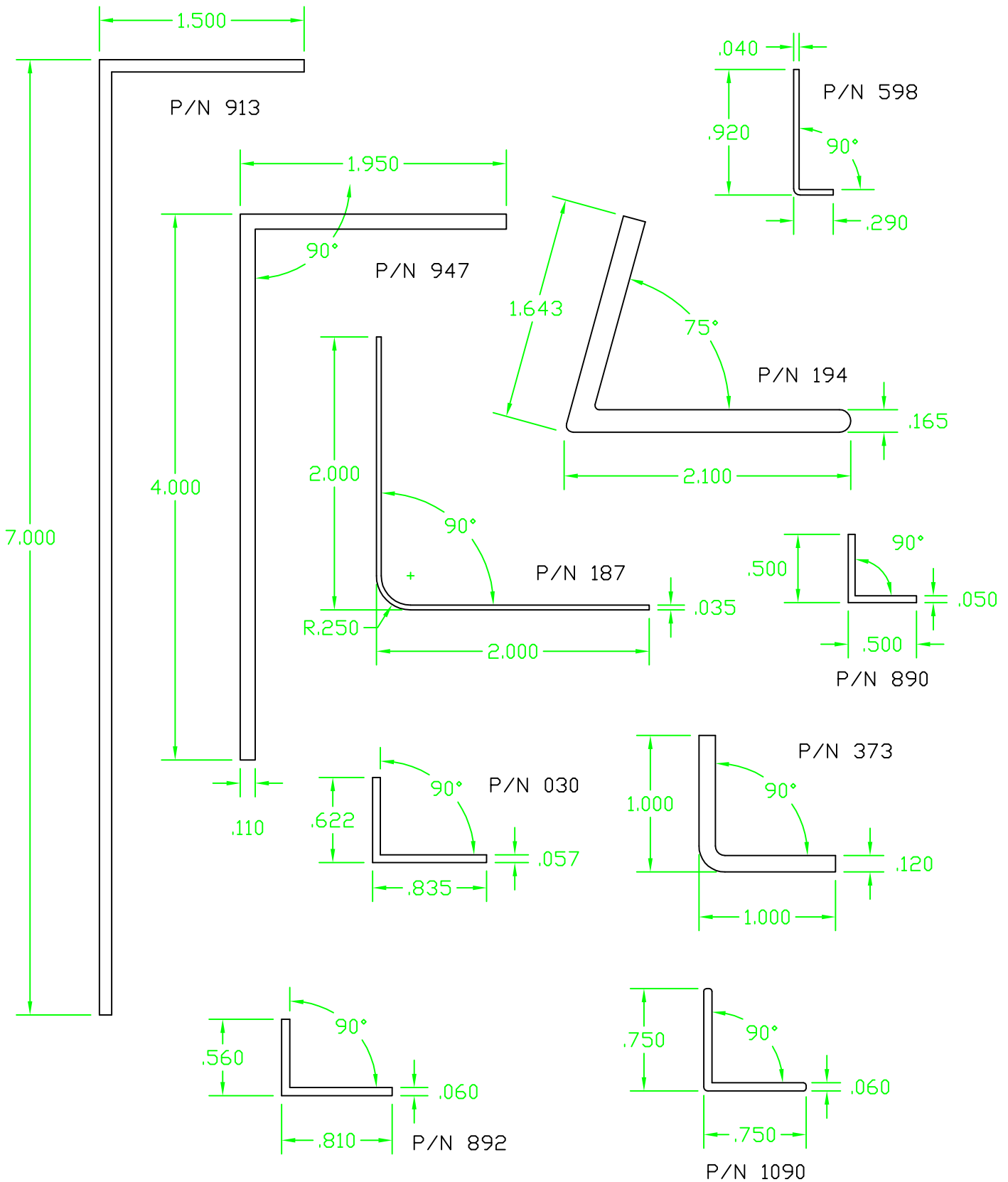

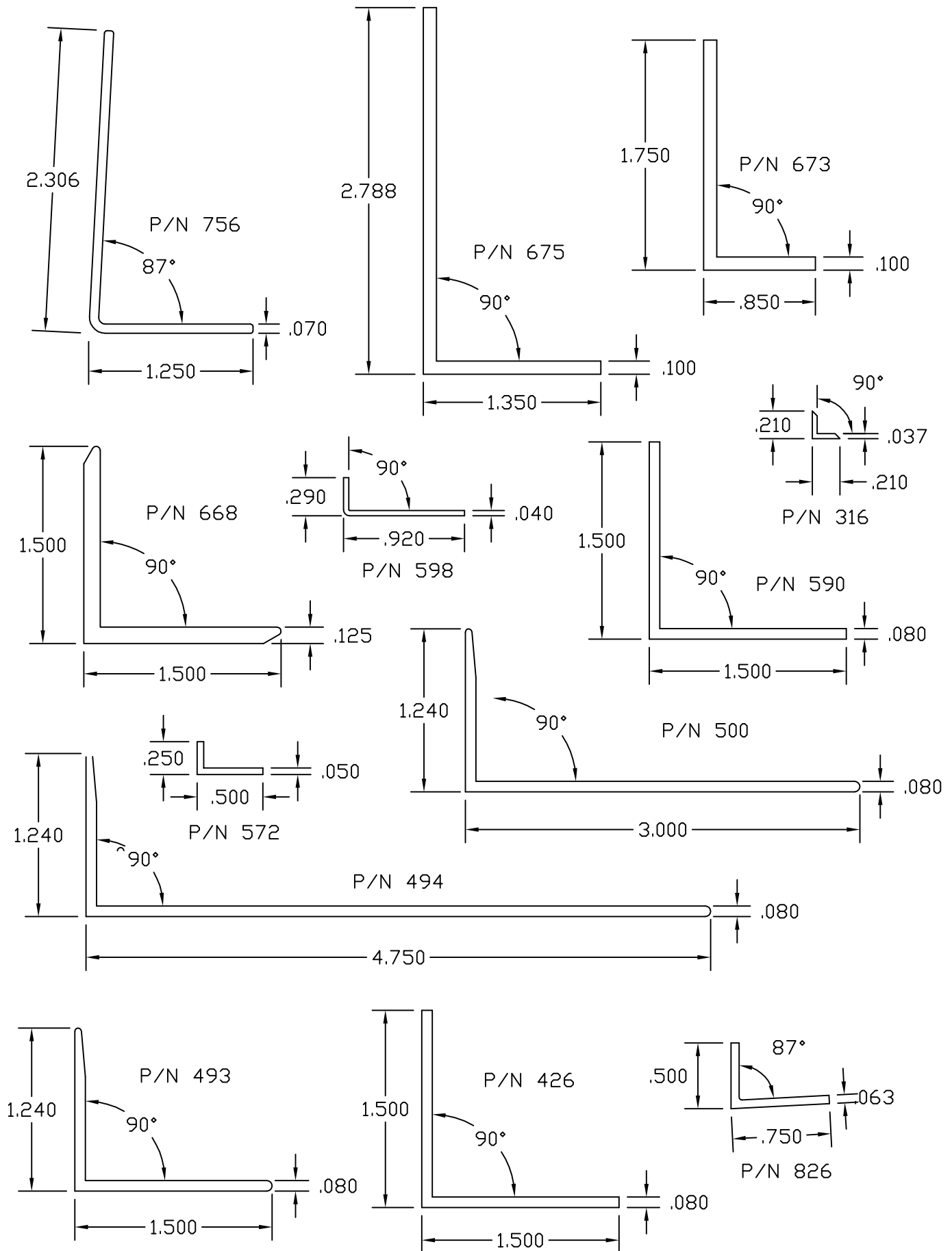

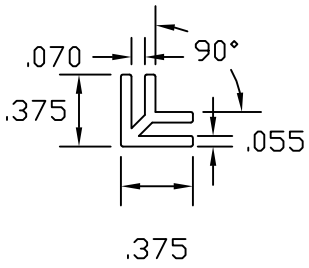

P/N 945

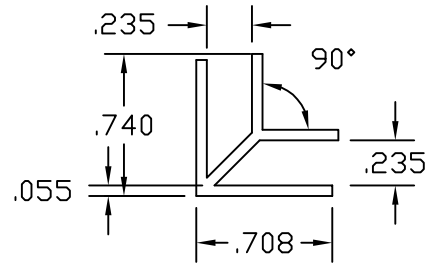

P/N 042

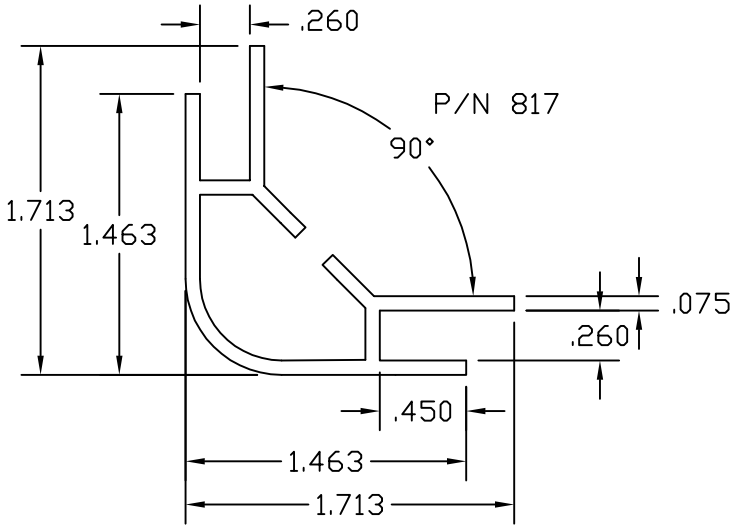

P/N 817

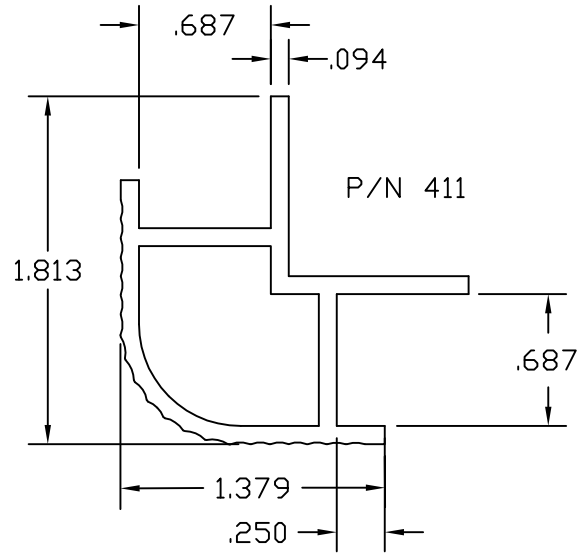

P/N 411

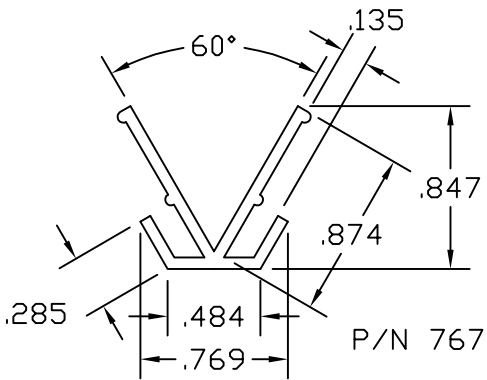

P/N 767

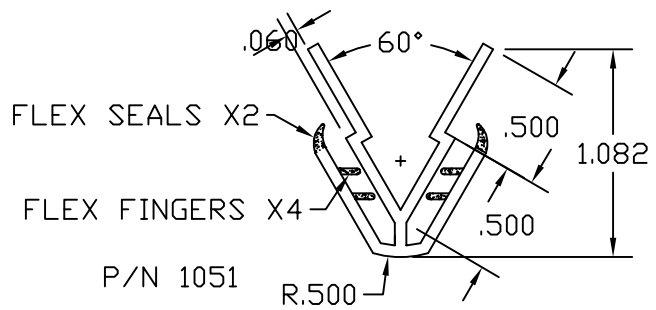

P/N 1051

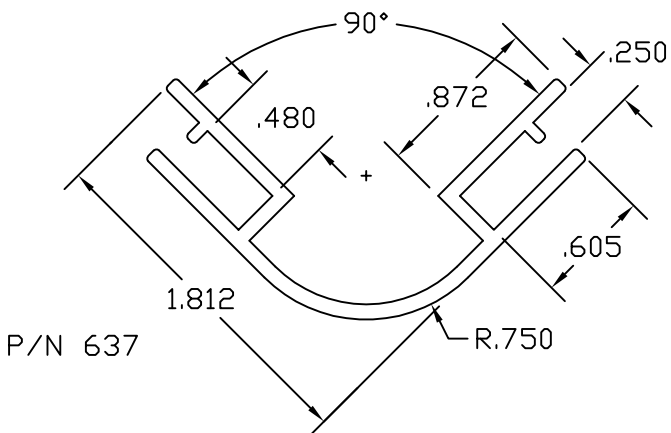

P/N 637

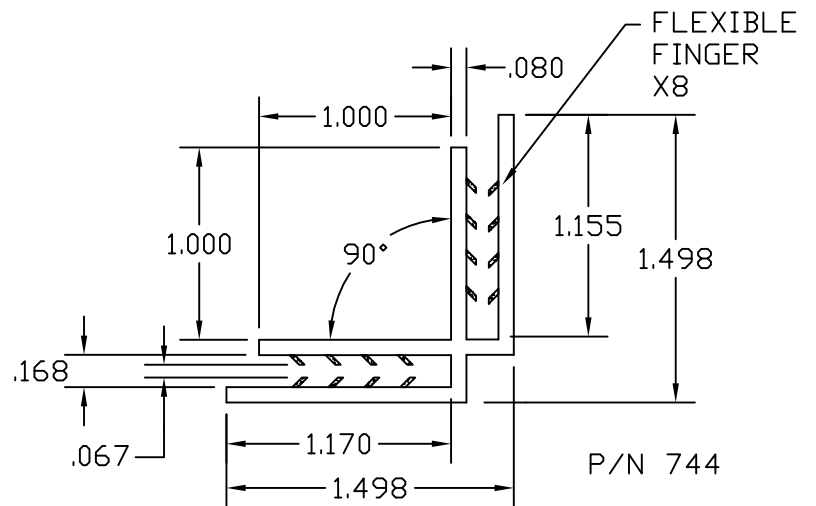

P/N 744



GRAPHIC HOLDERS

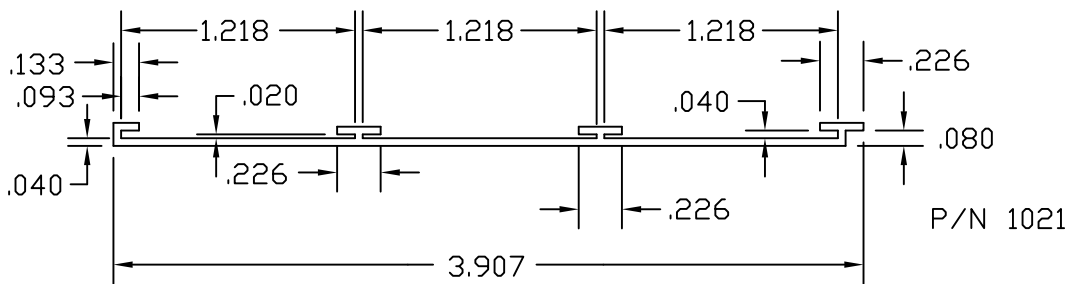
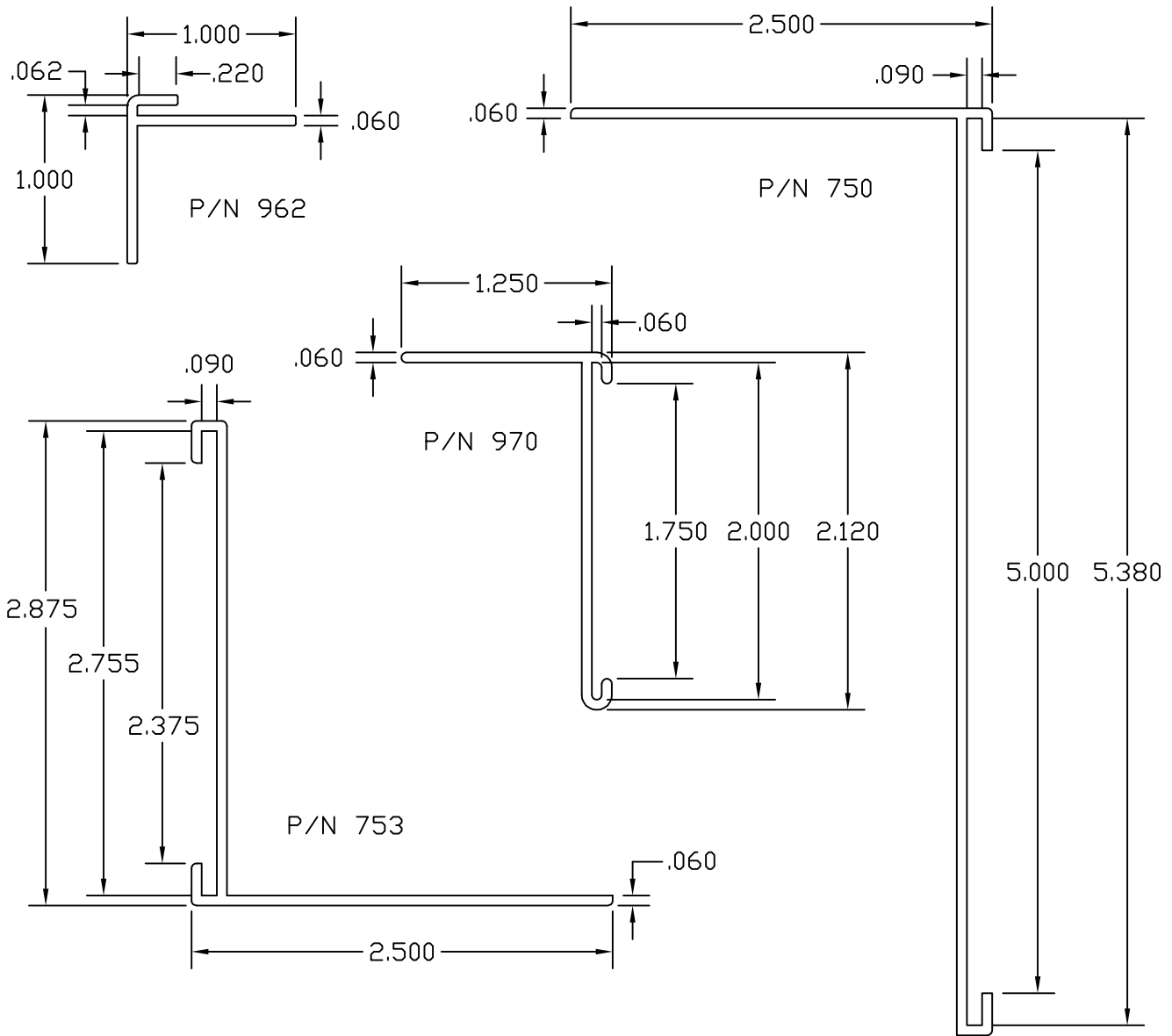

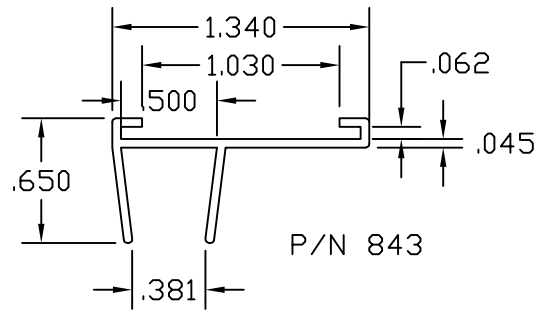
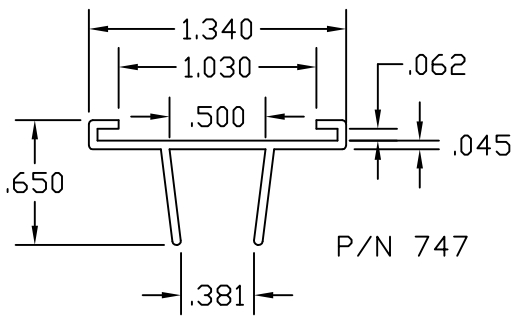
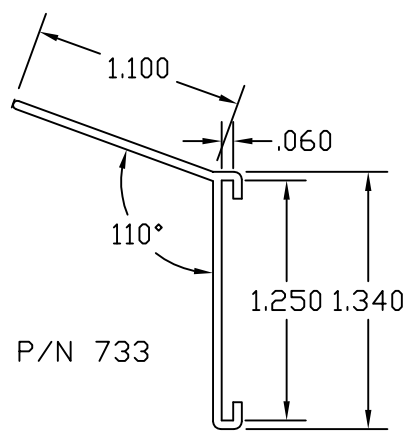
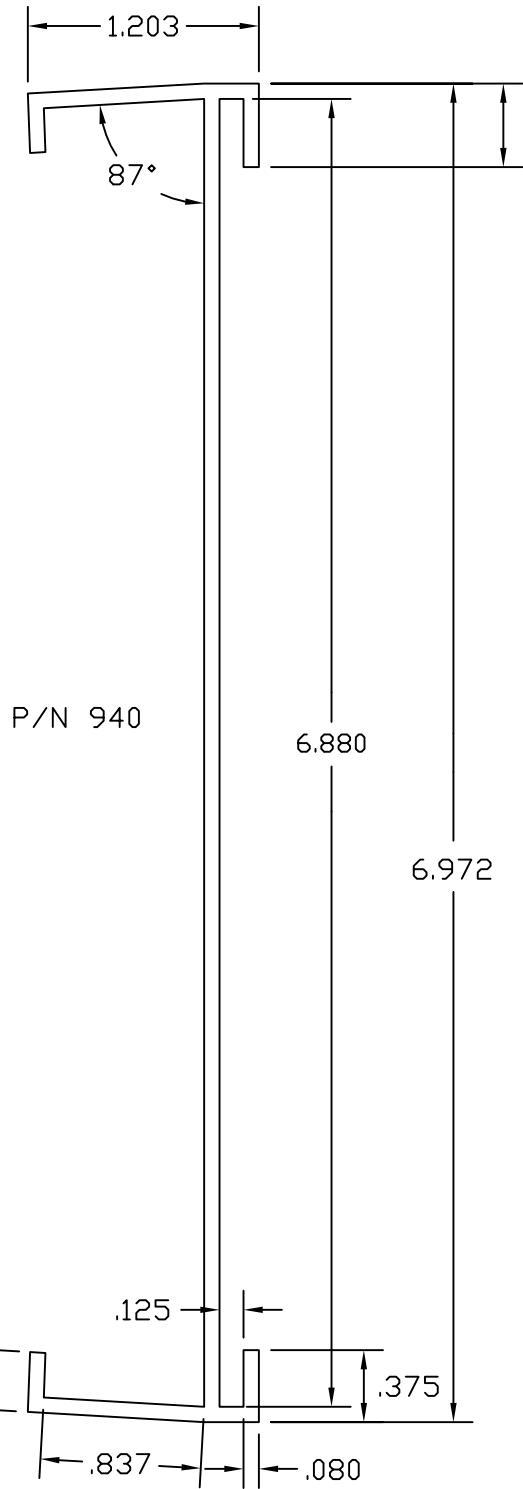
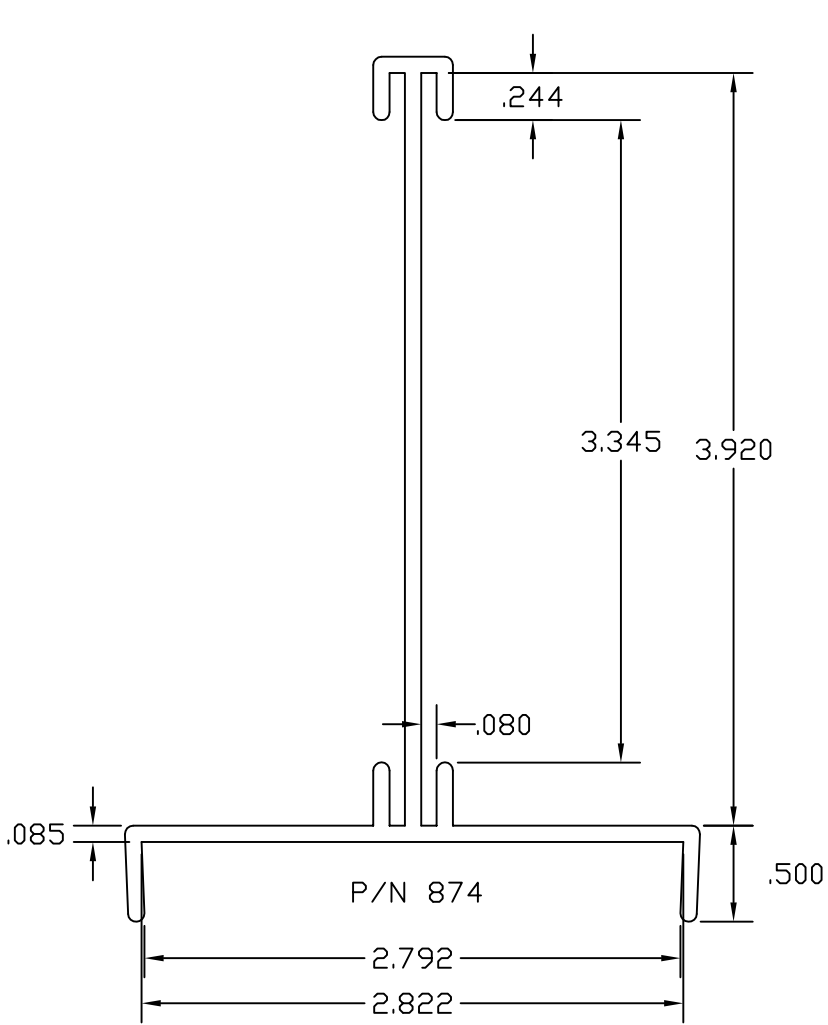

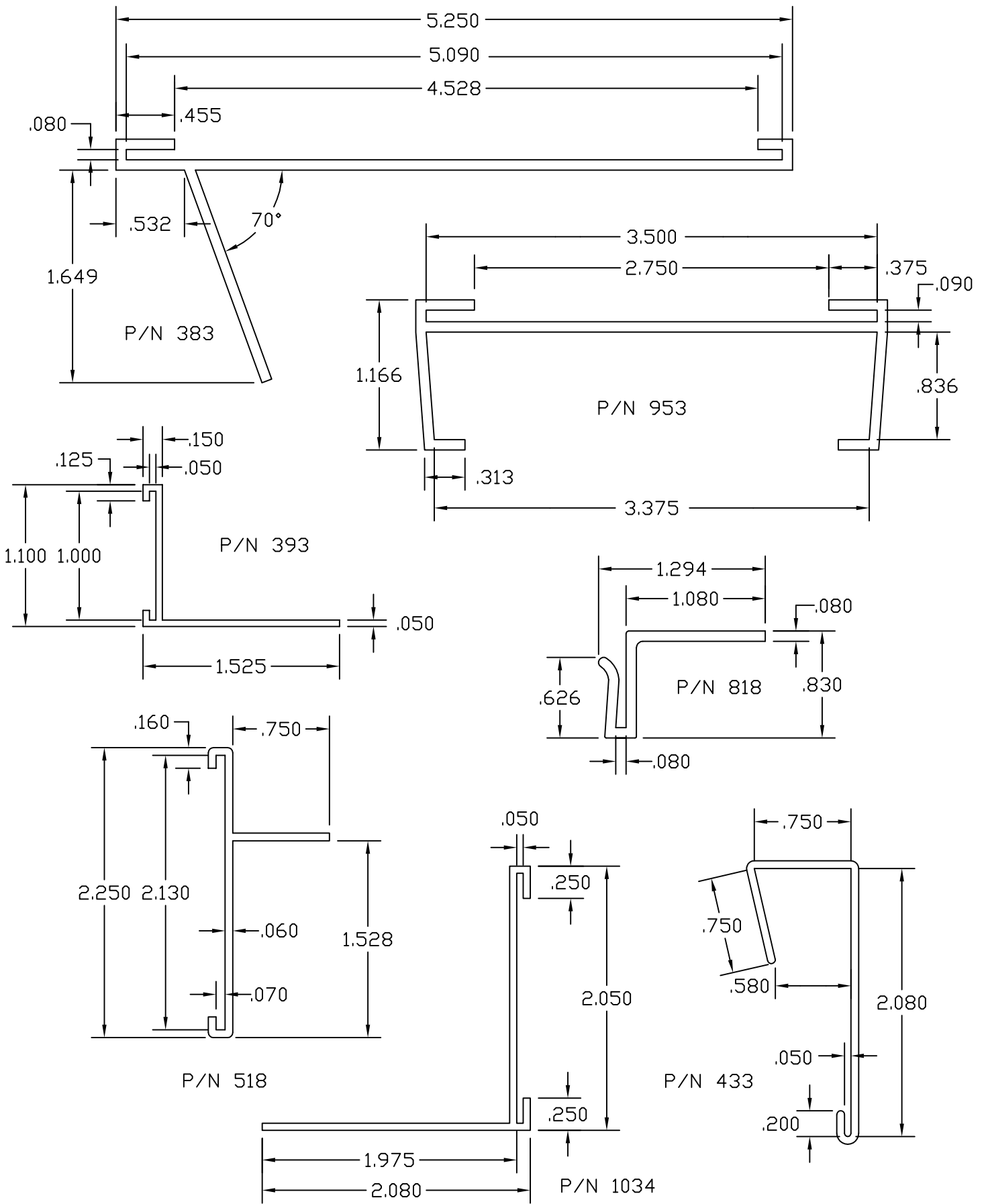

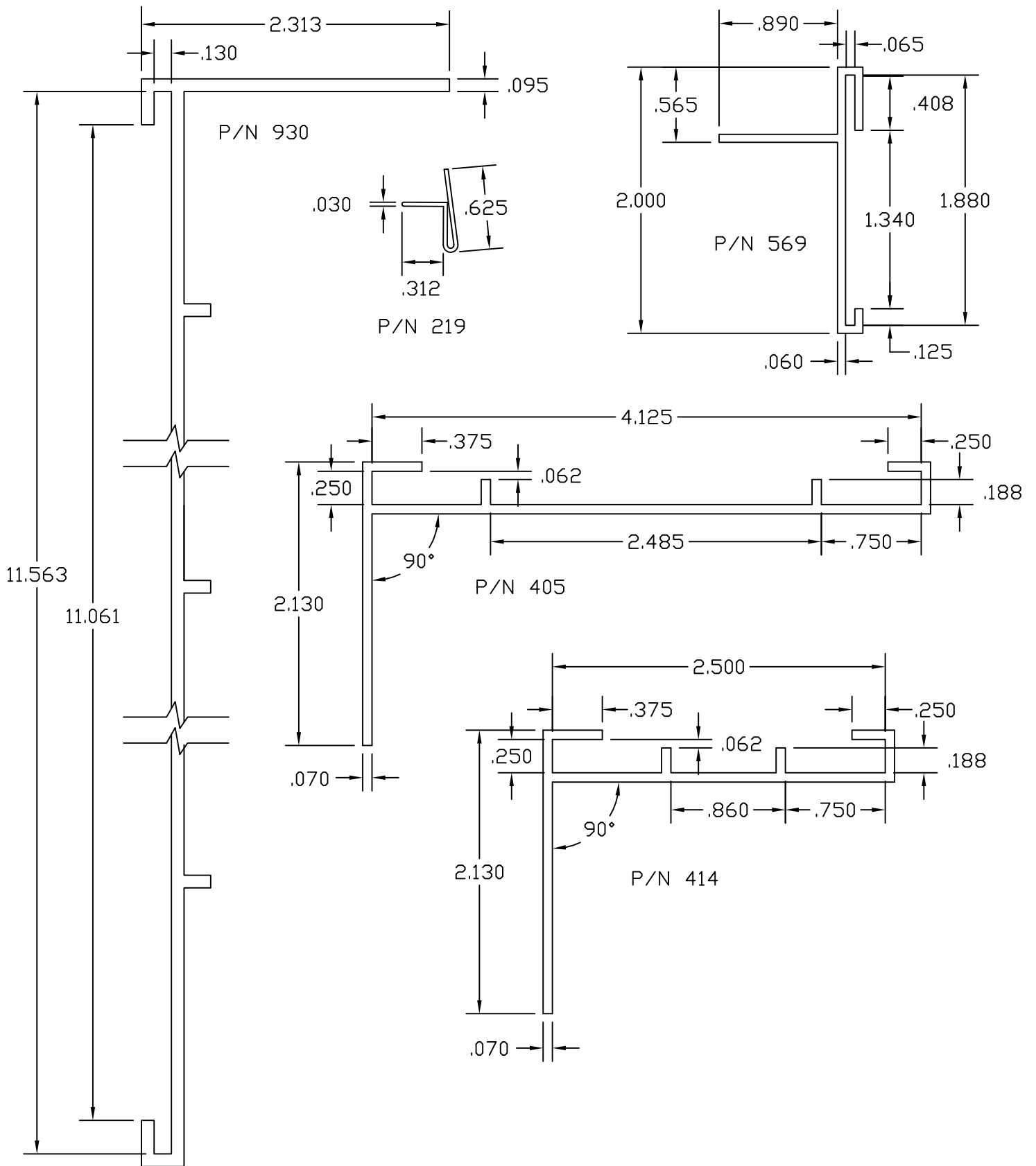

CO-EX HINGES

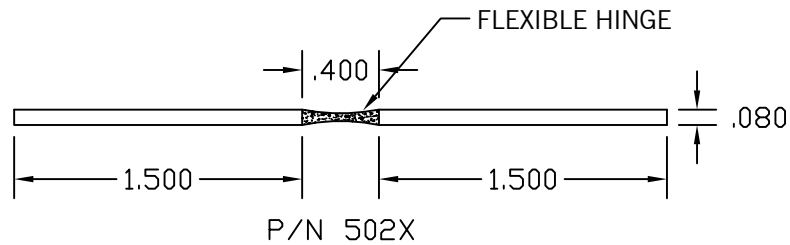
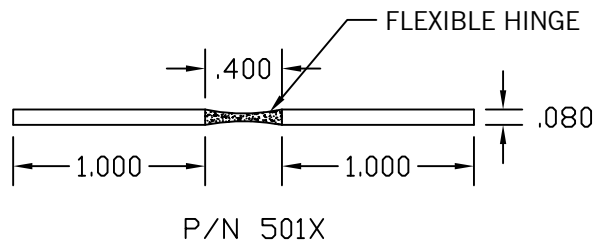
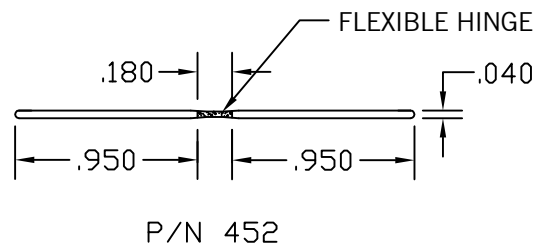
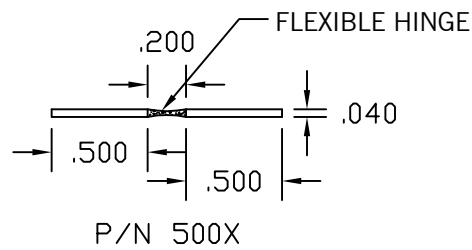
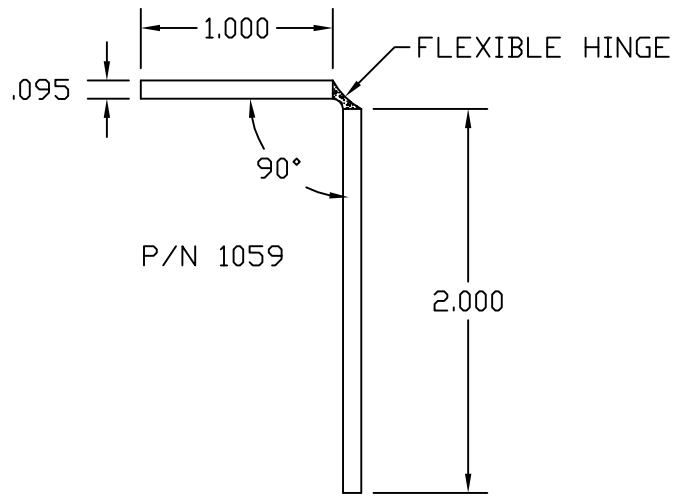

STRIPS

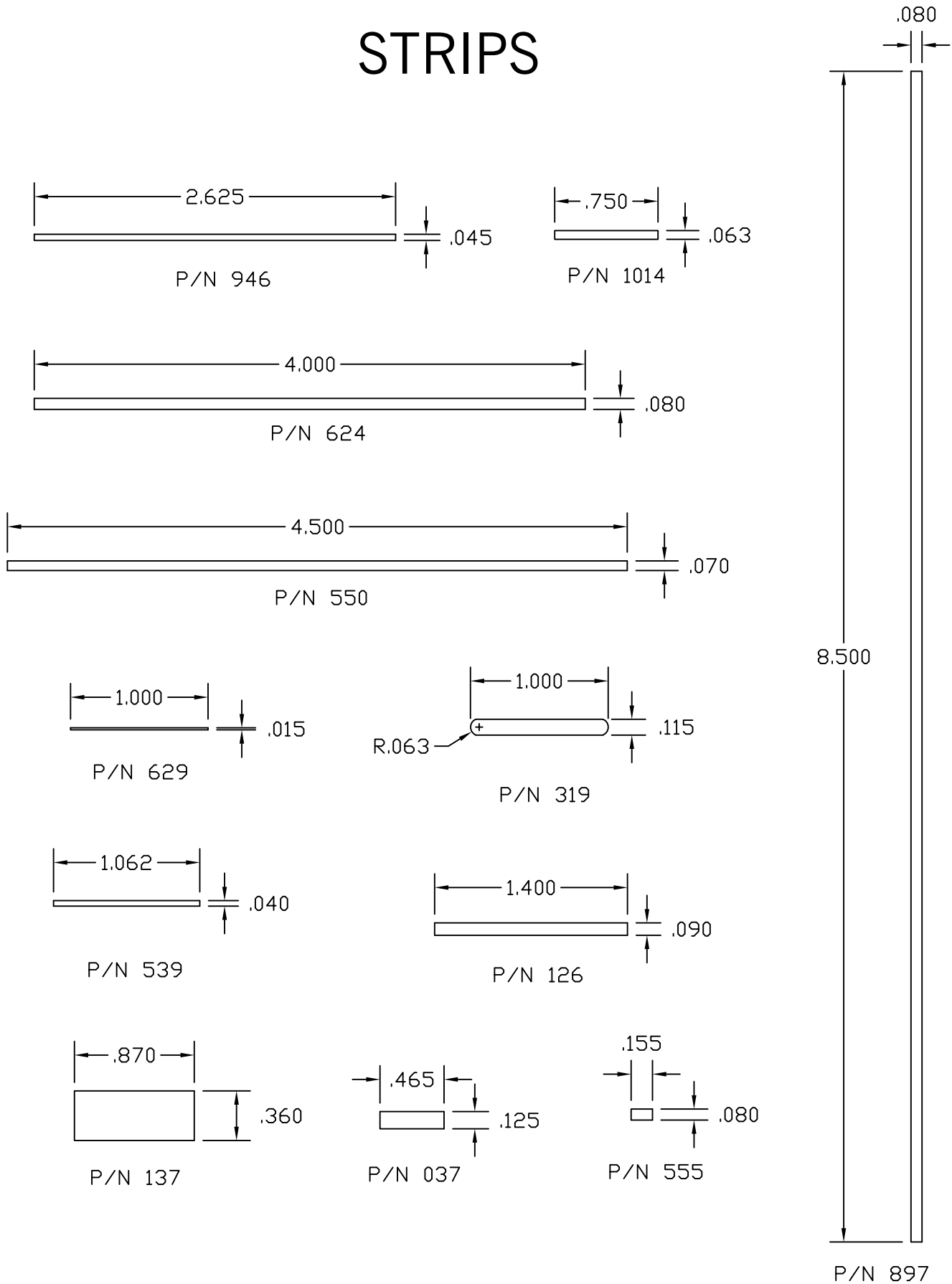

SHELF MANAGEMENT SYSTEMS

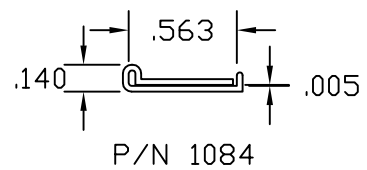
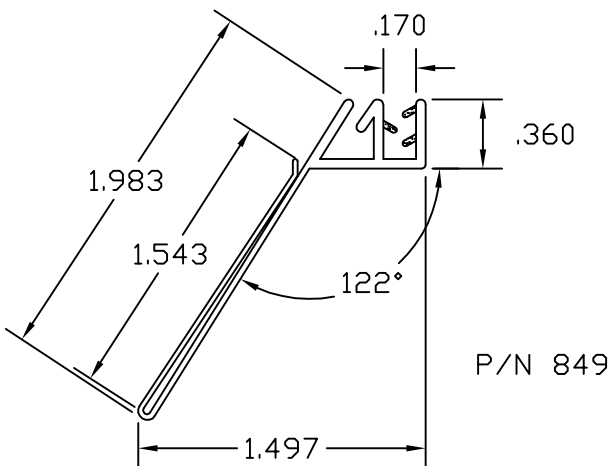
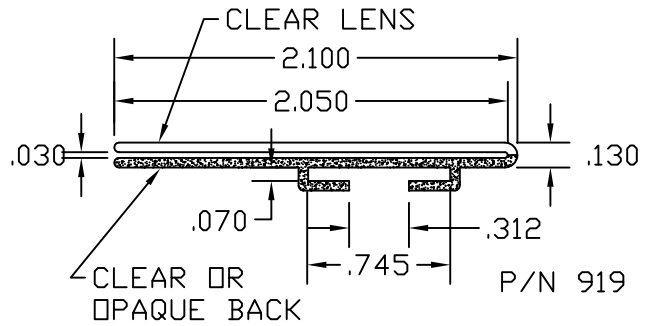
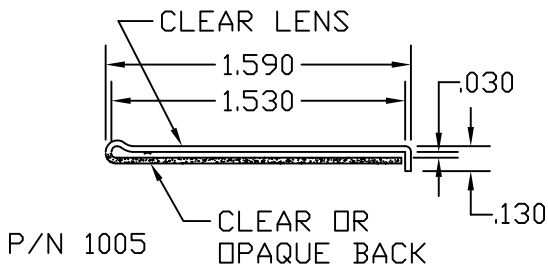
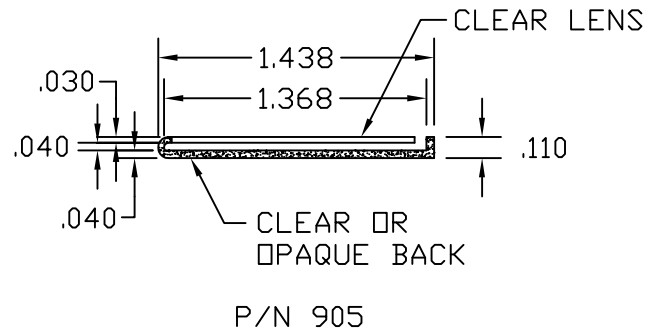
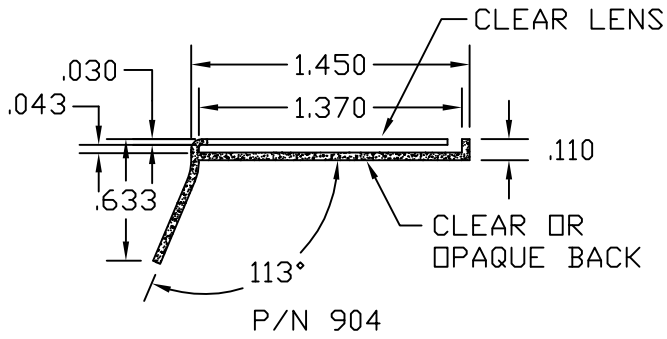

GRIPPER CHANNELS

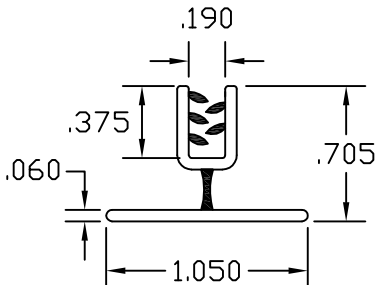

P/N 449

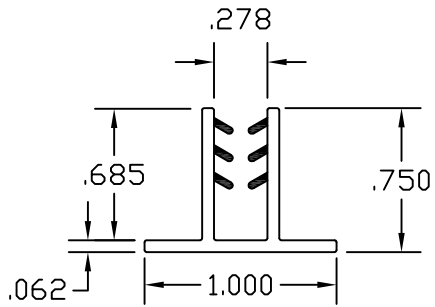

P/N 554

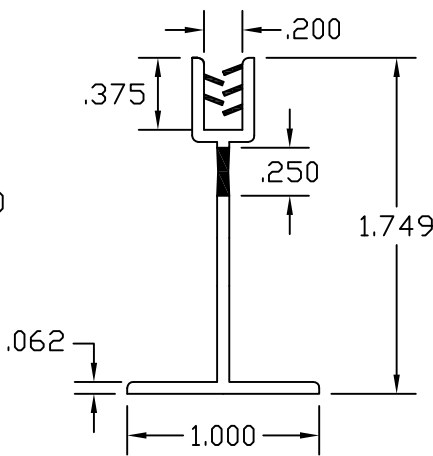

P/N 677

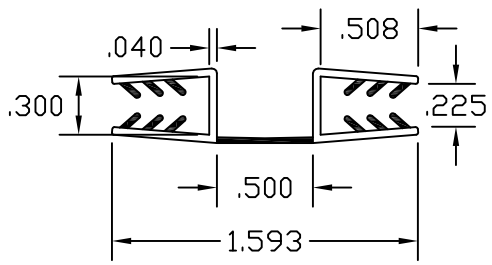

P/N 859

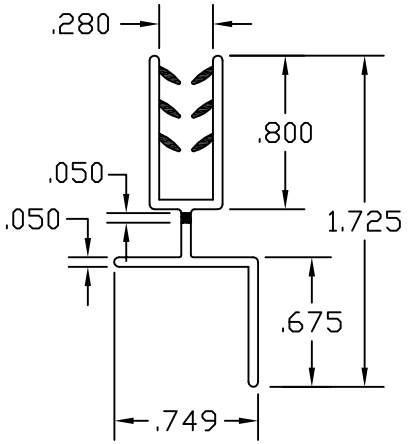

P/N 910

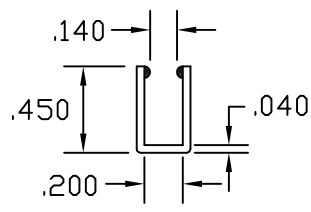

P/N 322

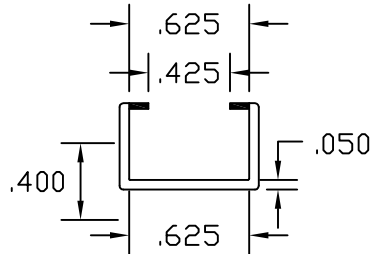

P/N 842



SHELF FRONTS

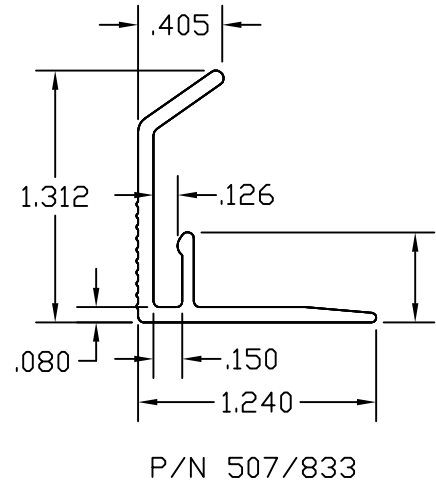
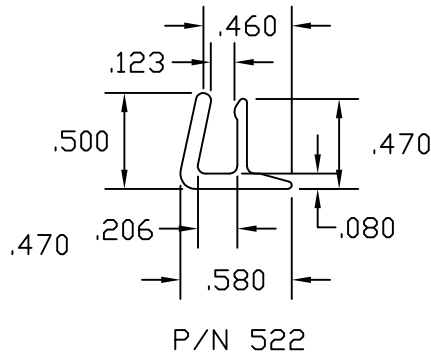
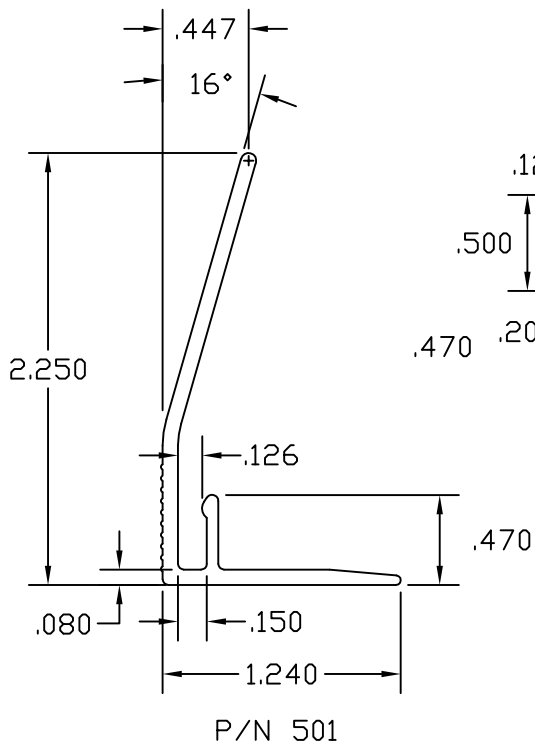

PRODUCT DIVIDERS

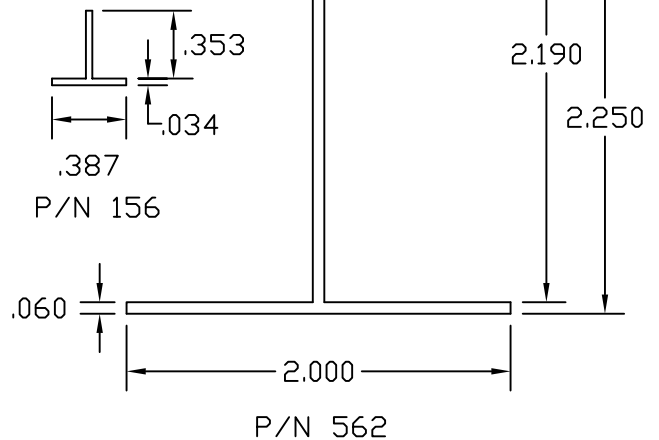
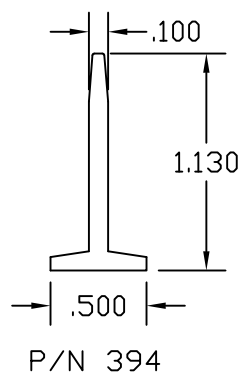
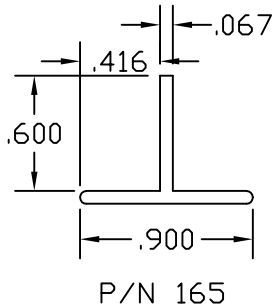
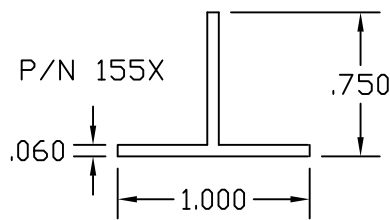
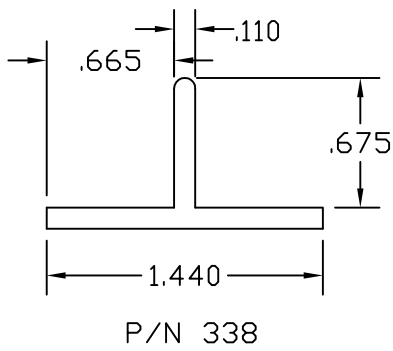

WIRE MANAGEMENT

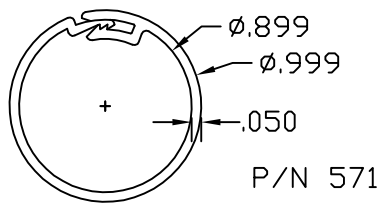

CLOSED

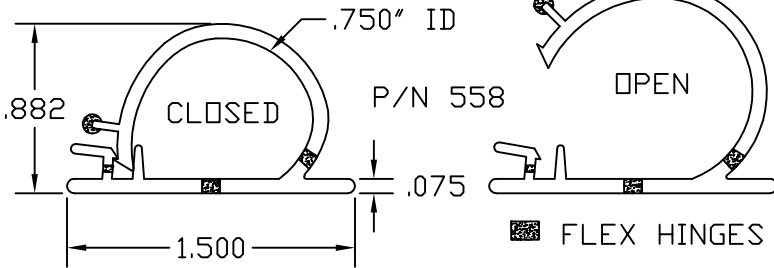
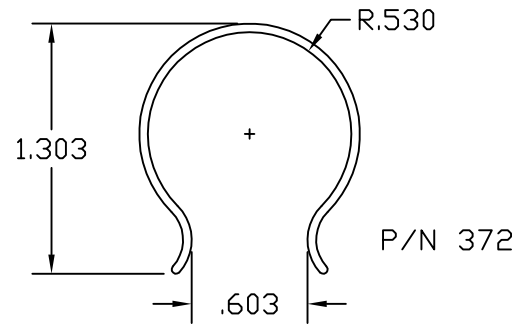
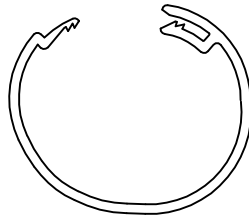

CLOSED

OPEN

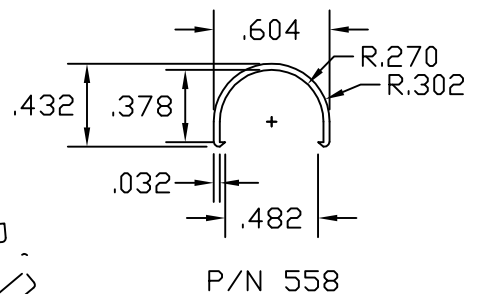
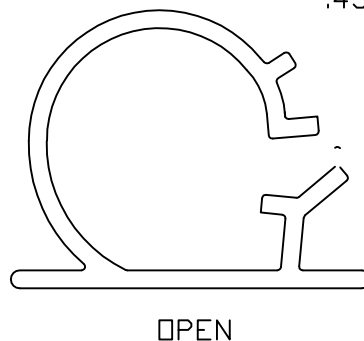
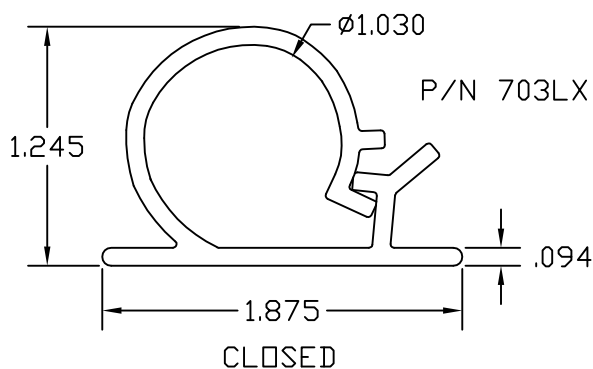
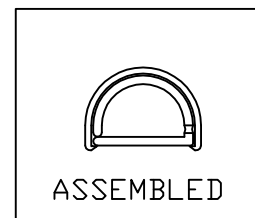
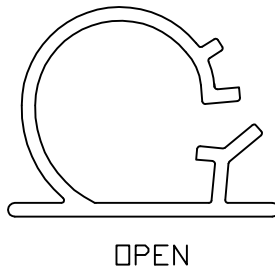
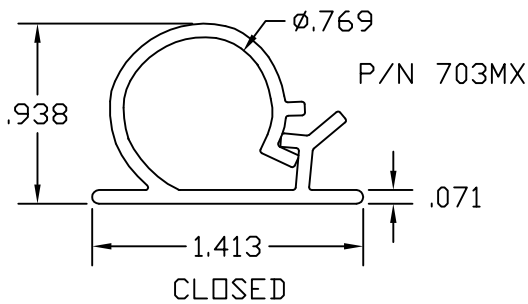
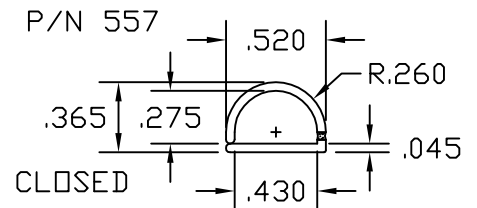
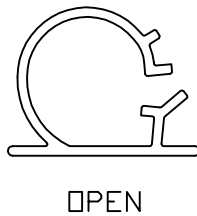
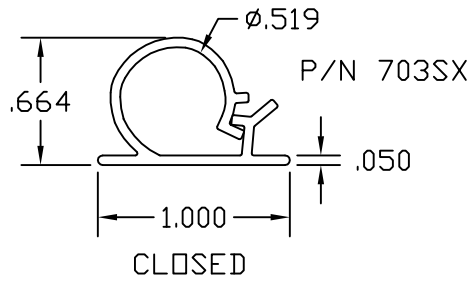
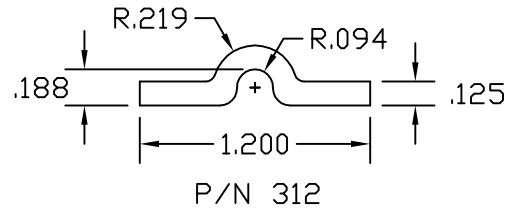

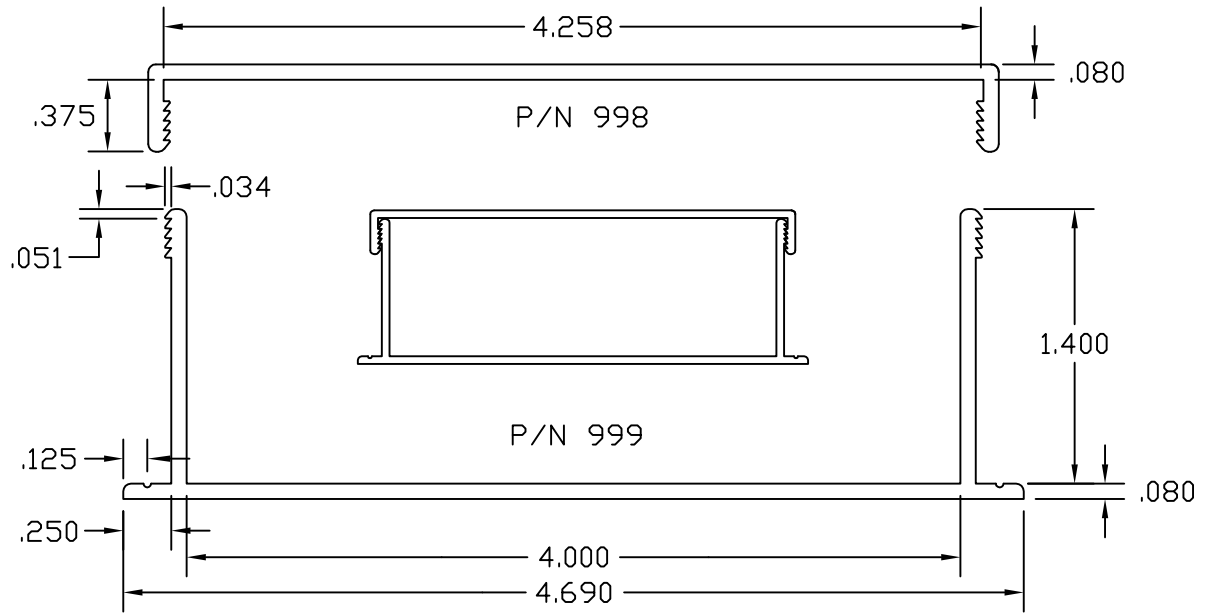

SLAT WALL

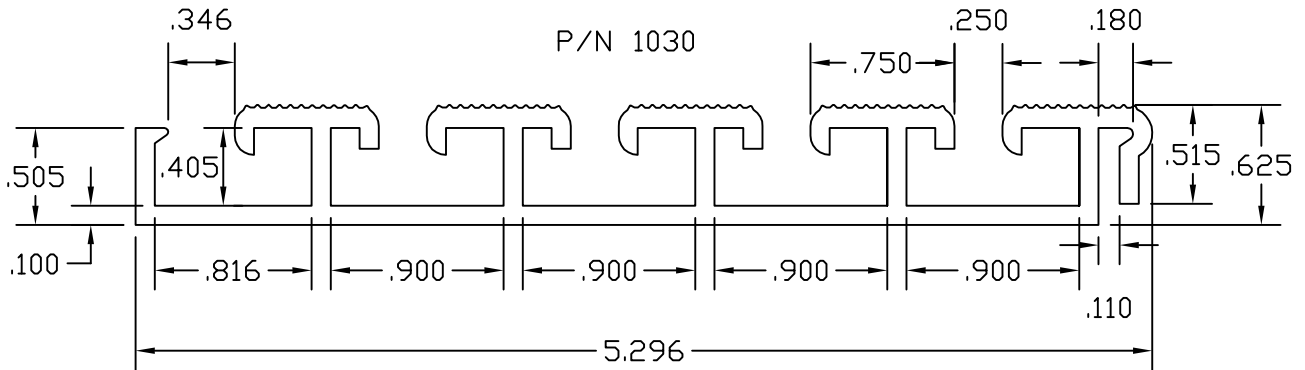

BANNER HANGER

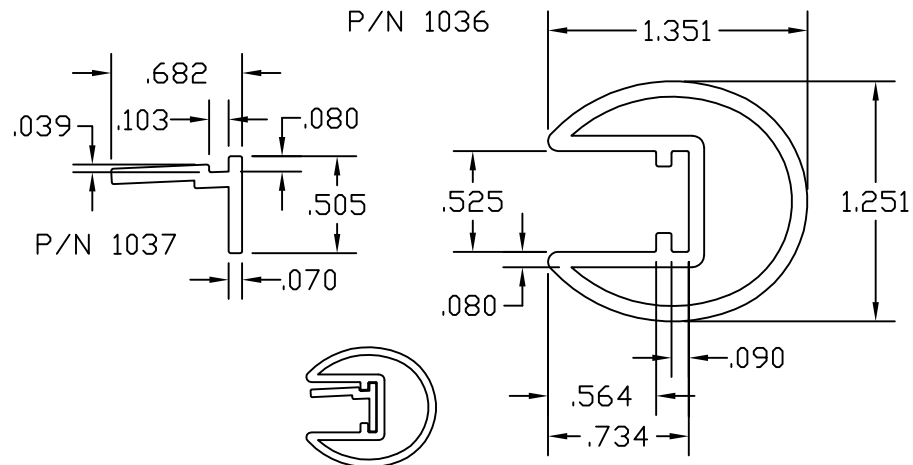

MISC. GRAPHIC & TICKET HOLDERS

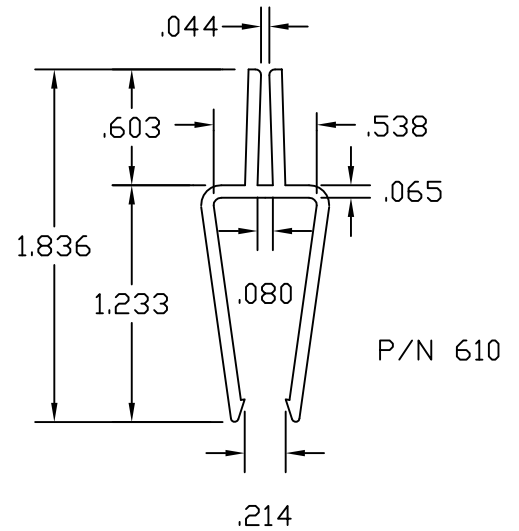
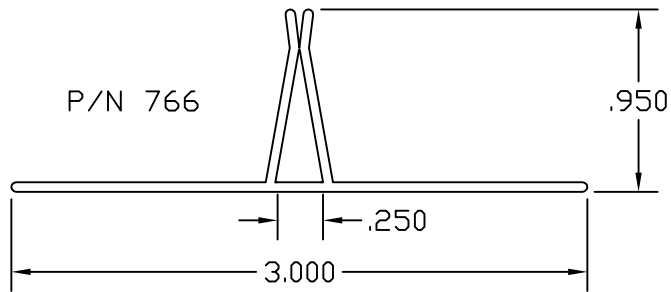
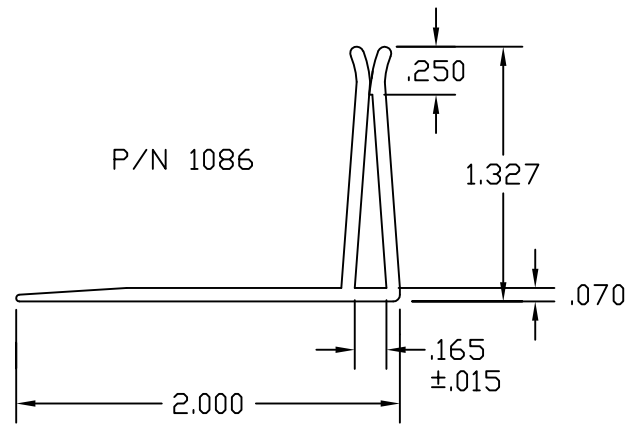
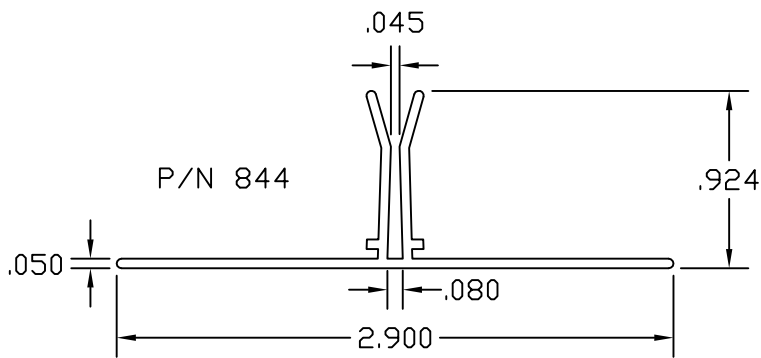

SELF LOCKING GRAPHIC HOLDERS

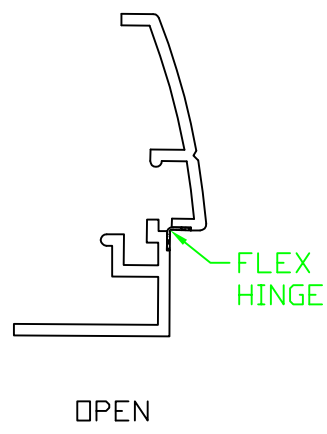
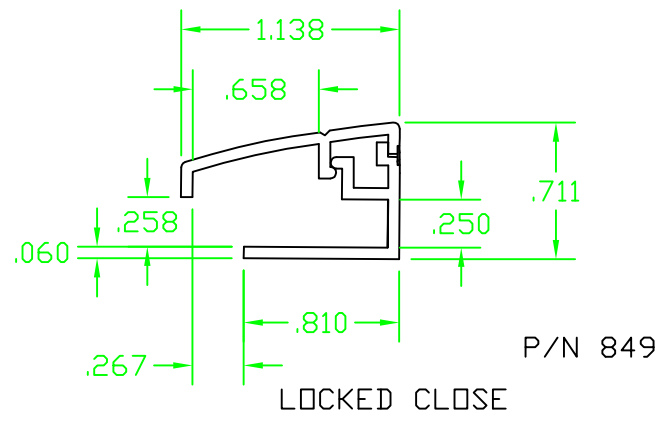
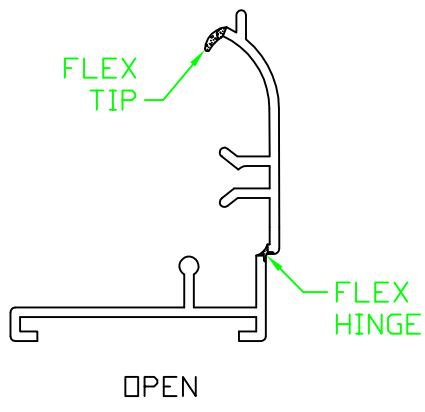
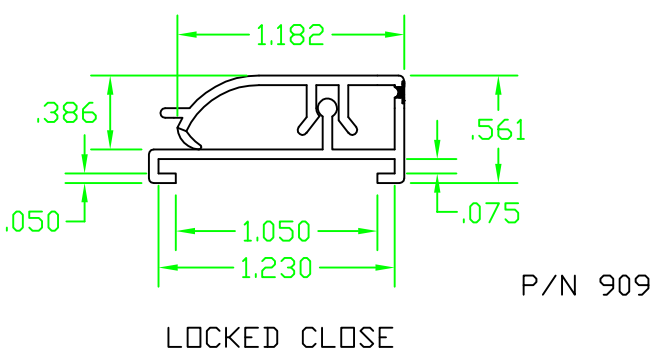
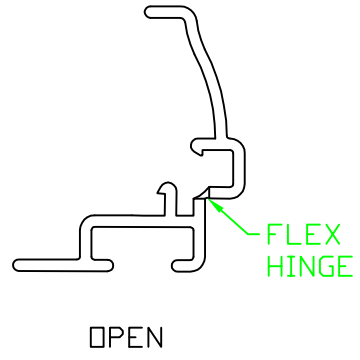
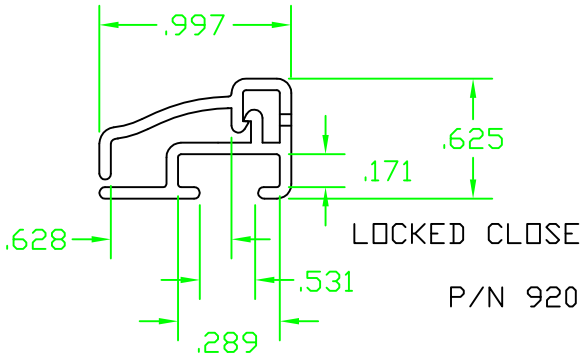

FLEXIBLE CAPPING

